



HEIDENHAIN



TNC 640

Contouring Control for
Machining Centers and
Milling/Turning Machines



September 2016

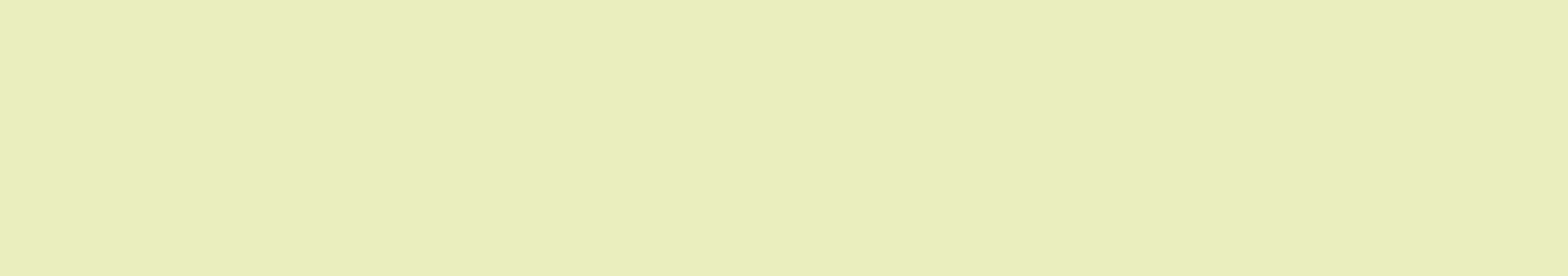

This brochure describes the functions and specifications of the TNC 640 with NC software 34059x-07

Contents

The TNC 640...

Where can it be used?	Versatile – The TNC contouring control for milling and milling/turning machines	4
What does it look like?	Well designed and user friendly – The TNC 640 in dialog with the user – The functional user interface	6
What can it do?	Multi-operation machining – Milling and turning on the same machine	10
	Quick and reliable machining with high contour accuracy – Dynamic Precision – The TNC 640 permits optimum tool movement – Machining and measuring 3-D contours	12
	Machining with five axes – Guided tool tip – Swivel head and rotary table controlled by the TNC 640	17
	Intelligent machining – Dynamic collision monitoring (DCM) – Dynamic Efficiency – Active chatter control (ACC) – Adaptive feed control (AFC) – Machining any contour slots with trochoidal milling	20
	Minimize setup times – The TNC 640 makes setup easy	26
	Automated machining – The TNC 640 measures, manages and communicates	28
How is it programmed?	Programming, editing, testing – The TNC 640 opens endless possibilities – Graphic support in any situation	30
	Programming in the workshop – Straightforward function keys for complex contours – Programming contours unconventionally – Field-proven cycles for recurring operations – Field-proven turning cycles – Reusing programmed contour elements – Fast availability of all information	32
	Open for communication – The TNC 640 understands CAD files – Uniformly digital order management and Connected Machining – The TNC 640 programming station	40
Are there any accessories?	Workpiece measurement – Setup, presetting and measuring with touch trigger probes	45
	Tool measurement – Measuring length, radius and wear directly in the machine	46
	Inspecting and optimizing machine accuracy – Calibrating rotary axes with KinematicsOpt	47
	Positioning with the handwheel – Delicate axis traverse	48
... At a glance	Overview – User functions, accessories, options, specifications, comparison of controls	49

Versatile

–The TNC contouring control for milling and milling/turning machines

For more than 35 years, TNC controls from HEIDENHAIN have been proving themselves in daily use on milling, drilling and boring machines, as well as machining centers. During this period the controls have been continuously developed with the needs of the machine operator always placed foremost.

You'll also find this principle realized in the TNC 640: workshop-oriented programmability with graphic support, many field-proven cycles and an operational design that you are familiar with from other HEIDENHAIN controls.

Shop-oriented programming

You program conventional milling and drilling operations, and with the TNC 640 also turning operations, yourself at the machine, in a Klartext plain-language dialog—the workshop-oriented programming language from HEIDENHAIN. The TNC 640 provides you with optimum support with practical prompts, questions and expressive graphical aids—for turning operations, too.

Standard operations and even complex applications are on call as a large variety of real-world machining cycles or coordinate transformations.

Easy to operate

For simple work, such as face milling or face turning, you need not write a program on the TNC 640. It is just as easy to operate the machine manually by pressing the axis keys or—for maximum sensitivity—using the electronic handwheel.

Offline program creation

The TNC 640 can be programmed remotely just as well. Its Ethernet interface guarantees very short transfer times, even of long programs.

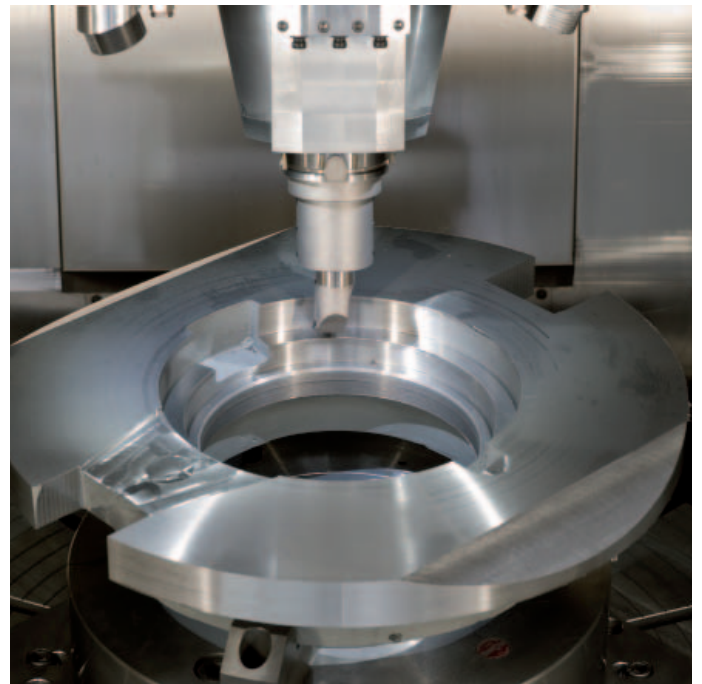
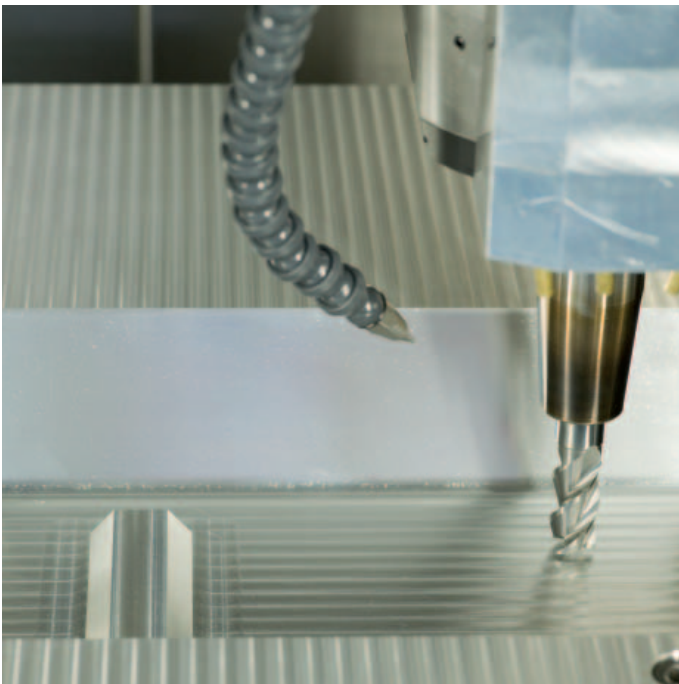

Universally applicable

The TNC 640 is particularly well suited for milling, turning, HSC, and 5-axis machining on machines with up to 18 axes.

The TNC 640 is especially attractive for the following areas of application:

Milling/turning machines

- Simple, program-controlled switchover between milling and turning
- Comprehensive turning cycle package
- Constant surface speed
- Tool-tip radius compensation

Universal milling machine

- Shop-floor programming with Klartext, the dialog-guided plain language from HEIDENHAIN
- Fast presetting with HEIDENHAIN touch probes
- Electronic handwheel

High-speed milling

- Fast block processing
- Short control-loop cycle time
- Motion control with smoothed jerk
- High spindle speed
- Fast data transfer

Boring mill

- Cycles for drilling, boring and spindle alignment
- Drilling oblique holes
- Control of quills (parallel axes)

Five-axis machining with swivel head and rotary table

- Tilting the working plane
- Cylinder surface machining
- Tool Center Point Management (TCPM)
- 3-D tool compensation
- Fast execution through short block-processing times

Machining centers and automated machining

- Tool management
- Pallet management
- Controlled presetting
- Datum management
- Automatic workpiece measurement with HEIDENHAIN touch probes
- Automatic tool measurement and breakage inspection
- Connection with host computer

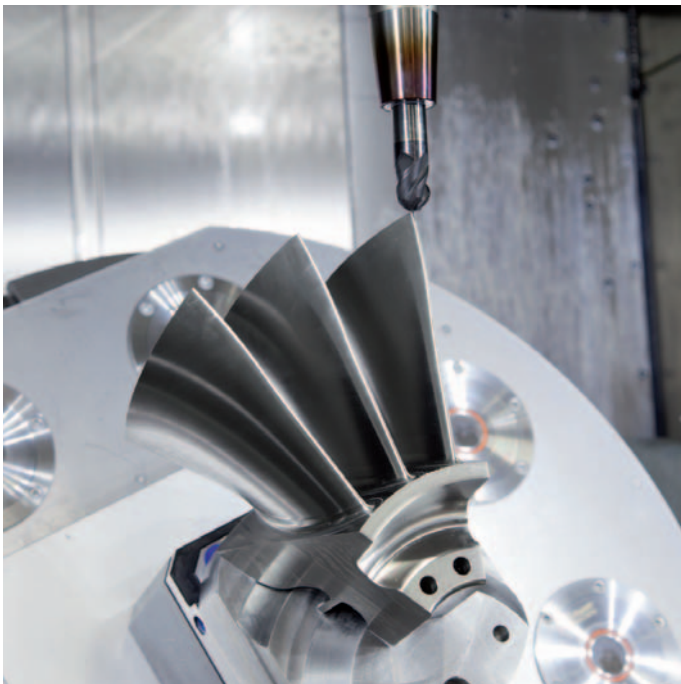

Well designed and user friendly

– The TNC 640 in dialog with the user

The screen

The large 19-inch-diagonal TFT color flat-panel display shows a clear overview of all relevant information for programming, operating, and inspecting the machine tool and control, such as program blocks, comments, and error messages. More information is provided through graphic support during program entry, test run, and actual machining.

The selectable "split screen" display shows the part program blocks in one half of the screen and the graphics or the status display in the other half.

During the course of the program, status displays will always offer information to keep you up to date on tool position, the current program, active cycles and coordinate transformations, and other data. The TNC 640 even shows the current machining time.

The operating panel

As with all TNCs from HEIDENHAIN, the operating panel is oriented to the programming process. The well-thought-out arrangement of keys in a clear division into **function groups**, i.e. programming modes, machining modes, management/ TNC functions, and navigation, supports you during program input. Simple key assignments and easily understandable symbols or abbreviations clearly indicate each key's function.

The **alphanumeric keypad** enables you to easily enter comments and G codes. The integrated **machine operating panel** features easily exchangeable snap-on keys that allow simple adaptation to the respective machine configuration. You use the **override potentiometers** to make delicate adjustments of the feed rate, rapid traverse, and spindle speed. And the operating panel features a complete **set of PC keys** and a **touchpad** that can be used, for example, for operating the DXF converter or the CAD viewer.

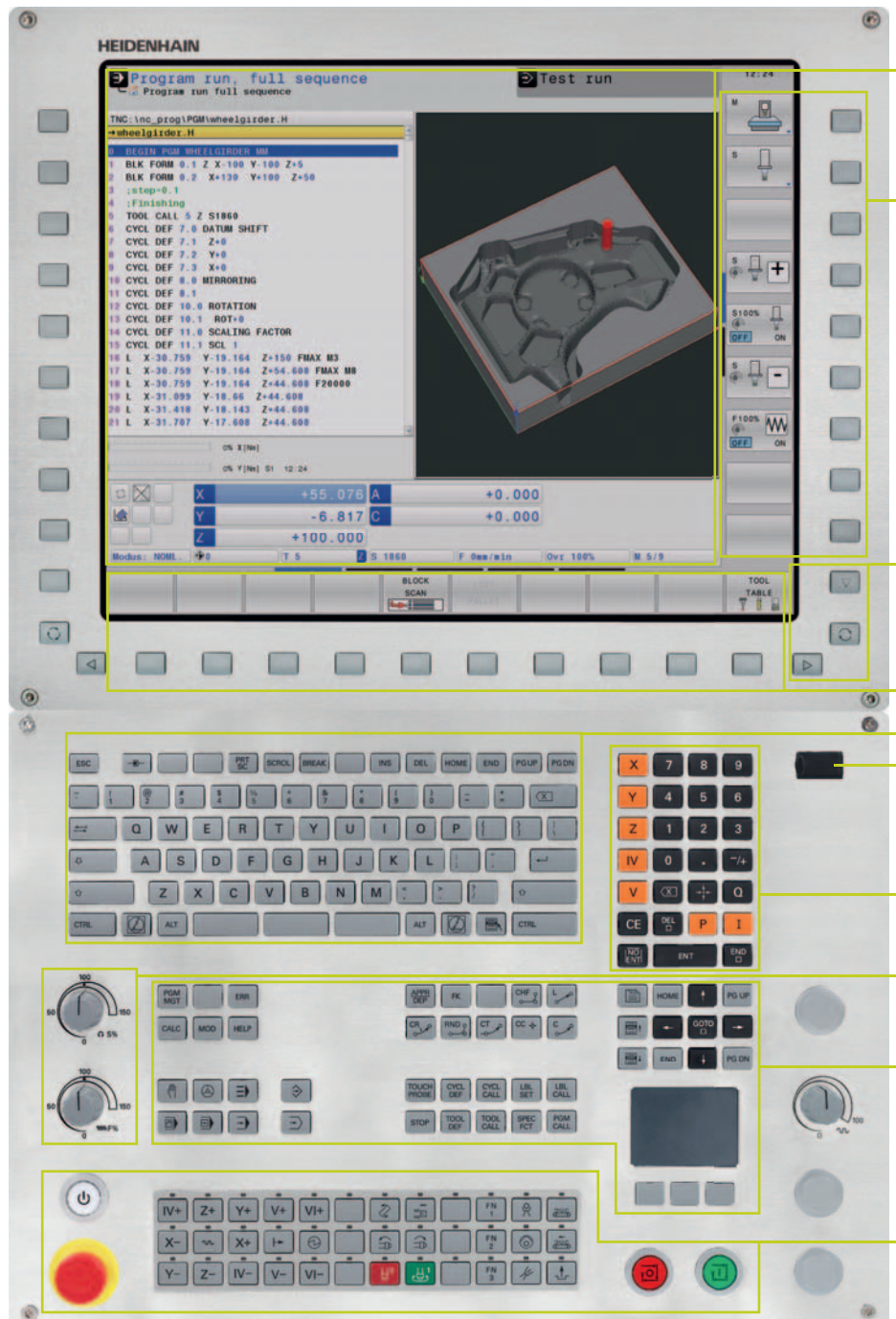

The screen content includes two operating modes, the program, graphics, and the machine status

PLC function keys (soft keys) for machine functions

Keys for **screen management** (screen layout), operating mode and switching between soft-key rows

Self-explanatory **function keys** (soft keys) for NC programming

Alphanumeric keyboard for comments or G codes and a **set of PC keys** for controlling the operating system functions

USB port for additional data storage or pointing devices

Axis-selection keys and **numeric keypad**

Override potentiometers for feed rate, rapid traverse and spindle speed

Function keys for programming modes, machine modes, TNC functions, management and navigation

Machine operating panel with snap-on keys and LEDs

Ergonomic and elegant, state-of-the-art and field-proven—HEIDENHAIN controls in a new design. Judge for yourself:

Durable

The high-quality stainless steel design of the TNC 640 features a special protection coating and is therefore highly resistant to soiling and wear.

Smooth

The rectangular, slightly rounded keys are pleasant to the touch and reliable in operation. Their inscriptions do not wear off, even under extreme workshop conditions.

Flexible

The integrated machine operating panel features easily exchangeable snap-on keys.

Reliable

The elevated key bed of the machine operating panel prevents accidental actuation. LEDs serve for status display of each key by clearly indicating the active machine functions.

Versatile

Soft keys both for the programming and the machine functions always show only the currently available selections.

Sensitive

With the handy control knobs you can individually adjust the feed rate, rapid traverse, and spindle speed.

Communicative

The fast USB 2.0 interface lets you connect storage media or pointing devices to the operating panel simply and directly.



Color-structured programs

The content of a program line can be quite comprehensive: line number, program function, input values, comment. To help you always find your way even in complex programs, the individual program elements on the TNC 640 are shown in different colors. The color syntax highlighting improves your overview when editing NC programs. It enables you to see at a glance, for example, where the editable input values are.

Uniform table editor

Regardless of which table you are editing—whether the tool table, datum table or pallet table—the appearance, function, and operation of the table editor are always the same.

Info line

In the info line, the TNC 640 shows the respective submode condition and helps you to orient yourself. The function is comparable to the history function in web browsers.

MOD function

The additional mode MOD offers a myriad of possible settings in a standardized layout regardless of the operating mode.

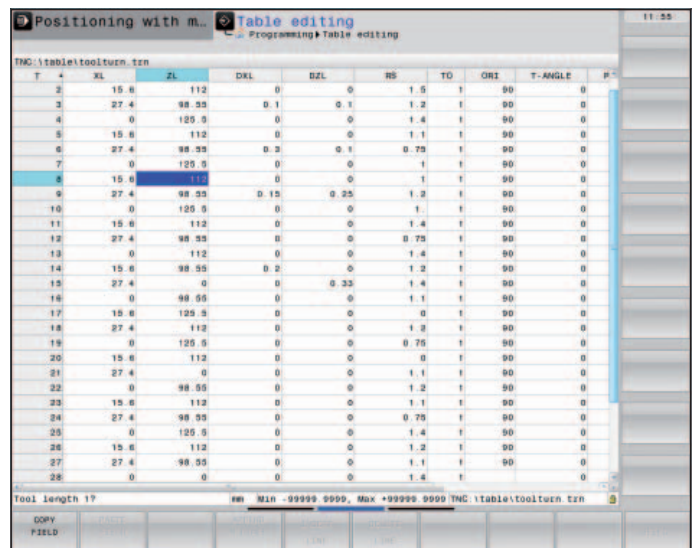
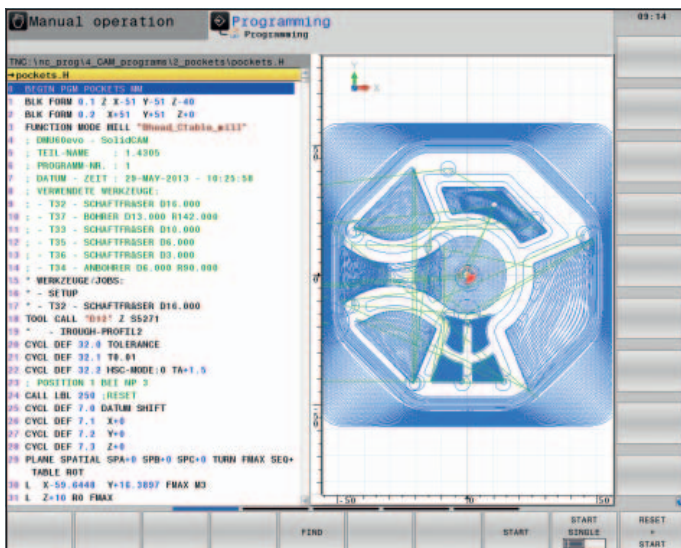

Multi-operation machining

– Milling and turning on the same machine (option)

Does your workpiece, after complex milling operations, also need to be set up on a lathe for several working steps? Do you have to plan for machine capacity, make tools, set up and fix the workpiece, and measure the finished part? The TNC 640 helps you to save time: on a milling/turning machine with TNC 640 you machine the complete workpiece on just one machine—milling, turning, milling, in whatever sequence you choose. After performing all operations on this one machine, you measure the finished workpiece with a HEIDENHAIN touch probe.

The TNC 640 offers you powerful functions that enable the NC program to easily switch between turning and milling as desired under program control. This gives you the complete freedom to decide how and when you want to combine the two machining methods. And of course, the operations switch back and forth regardless of the machine and its axis configuration. During switchover, the TNC 640 assumes all necessary internal changes, such as switching to diameter display, setting the datum in the center of the rotary table, and even machine-dependent functions such as clamping the tool spindle.*

Programming as accustomed

You can program the turning operations—as always—conveniently under dialog guidance in Klartext, the plain-language format from HEIDENHAIN. Besides the standard path functions you can also use FK free contour programming to easily create contour elements not dimensioned for NC. Beyond this, you also have the contour elements recessing and undercutting for turning operations, which are supported by expressive help illustrations.

If a contour is available in DXF format, you can easily import it with the aid of the DXF converter (option).

*The machine must be prepared by the machine tool builder for this function.



Cycles for milling and turning

HEIDENHAIN controls have always been known for their comprehensive and technologically sophisticated package of cycles. Frequently recurring operations that comprise several steps are also stored in the TNC 640 as cycles. You program them under conversational guidance and are supported by enlightening help graphics that clearly illustrate the required input parameters. Besides the well known TNC milling and drilling cycles, the TNC 640 also offers a wide variety of turning cycles, for example for roughing, finishing, recessing, thread turning and recess turning. The field-

proven HEIDENHAIN lathe controls provide the software basis for the turning functions. They enable you to program even demanding turning operations very easily at the machine.

In the more sophisticated contour turning cycles, the TNC 640 uses the same techniques as are used for milling. Here, too, there is no need for the TNC programmer to learn new ways of programming—he can continue to rely on what he already knows and quickly find his way into the world of turning on a milling machine.

Interpolation turning

You can manufacture ring nuts, recesses, tapers or any turning contours not only using conventional turning, but also through interpolation turning. During interpolation turning, the tool executes a circular movement with the linear axes. The cutting edge is always oriented to the center of the circle for outside machining, or away from the center for inside machining. By varying the circle radius and the axial position, any rotationally symmetric objects can be produced—even in the tilted working plane. The TNC 640 offers two cycles for interpolation turning:

- Cycle 291 switches on the coupling between the spindle positions and axis positions. You can then program any desired axial or radial tool movements
- Cycle 292 switches on the spindle coupling and then automatically controls the machining of a programmed turning contour



Quick and reliable machining with high contour accuracy

– Dynamic Precision

dynamic + precision

The control design from HEIDENHAIN guarantees not just very high accuracy and surface quality, but high machining speeds as well—regardless of whether you are milling or turning. These are made possible by various technologies, cycles, and functions. Individually or in combination, they ensure optimized motion control, effective jerk limiting, and dynamic contour look-ahead, and therefore perfect surfaces with very short machining times.

The hypronym **Dynamic Precision** stands for a number of HEIDENHAIN solutions for metal cutting that can dramatically improve the dynamic accuracy of a machine tool. It is the result of a new perspective on the competing demand for accuracy, high surface quality and short machining times. The dynamic accuracy of machine tools manifests itself in deviations at the tool center point (TCP). These deviations depend on kinetic quantities such as velocity and acceleration (also jerk), and are caused, in part, by vibrations of machine components.

All these influences are together responsible for dimensional inaccuracies and faults in the workpiece surface. They therefore have a decisive influence on quality and, when poor-quality parts are scrapped, also on productivity. Dynamic Precision counteracts these problems with intelligent control technology to enable designers to further improve the quality and dynamic performance of machine tools. That saves time and money in production.

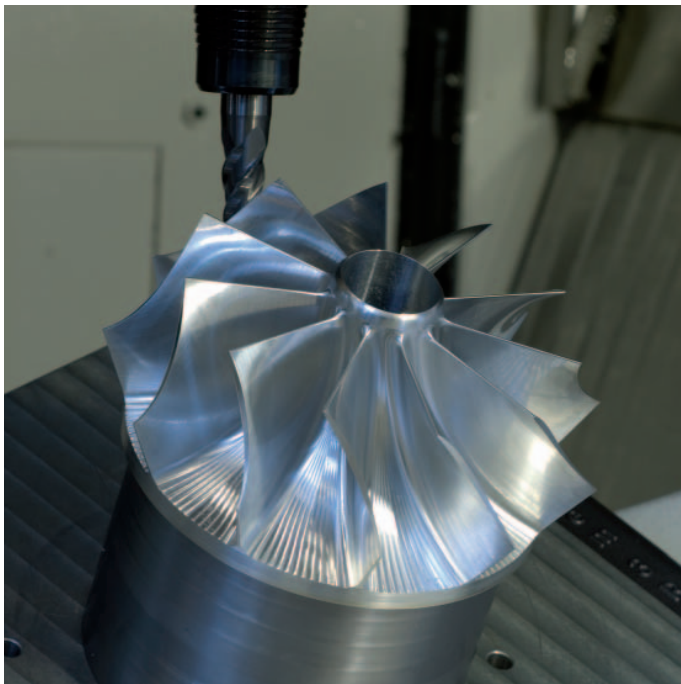

Dynamic Precision includes the following functions:

- **CTC** – Compensation of acceleration-dependent position errors at the TCP
- **AVD** – active damping of drive train and machine setup vibrations
- **PAC** – Position-dependent adaptation of controller parameters
- **LAC** – Load-dependent adaptation of control parameters
- **MAC** – Motion-dependent adaptation of control parameters

The machine tool builder can use the options comprised by **Dynamic Precision** either individually or in combination. The advantages of functions at a glance:

- **CTC**: Higher accuracy in acceleration phases
- **AVD**: Better surfaces
- **CTC+AVD**: Faster and more precise machining
- **PAC**: Greater contour accuracy
- **LAC**: Higher accuracy regardless of the load
- **MAC**: Less vibration, higher maximum acceleration during rapid traverse

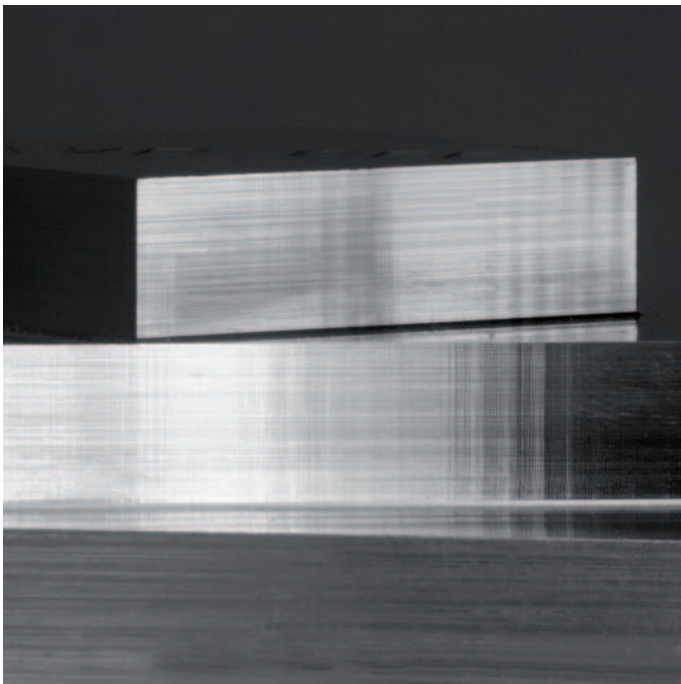

Vibrations can significantly impair surface quality

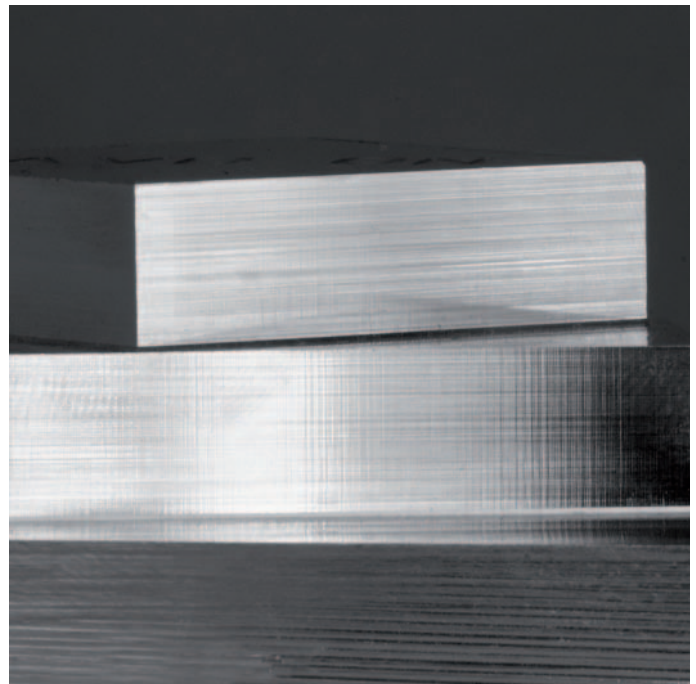

With AVD, visibly superior surface quality is achieved

Quick and reliable machining with high contour accuracy

– The TNC 640 permits optimum tool movement

Very high contour accuracy and surface quality

TNC controls from HEIDENHAIN are known for their **jerk-smoothed as well as velocity- and acceleration-optimized motion control**. In this way they ensure optimized surface quality and workpiece accuracy. With the TNC 640 you can exploit state-of-the-art developments. The TNC 640 looks ahead, thinks along with you, and can calculate the contour dynamically before machining. Special filters specifically and additionally suppress machine-specific natural vibration.

With **look-ahead**, the TNC 640 recognizes directional changes beforehand and adapts the traversing speed to the course of the contour and the surface to be machined. You simply program the maximum machining velocity as feed rate and, in **Cycle 32 TOLERANCE**, enter in the control the maximum permissible deviations from the ideal contour. The TNC 640 automatically adapts the machining to the tolerance that you define. No contour damage occurs with this method.

Advanced Dynamic Prediction (ADP)

ADP expands the previous advance calculation of the permissible maximum feed rate profile. ADP compensates differences in feed rate profiles resulting from point distribution on neighboring paths, especially in NC programs from CAM systems. This provides, among other things, a particularly symmetric feed rate behavior on the back-and-forth path during bidirectional finish milling, as well as very smooth feed rate curves on parallel milling paths.

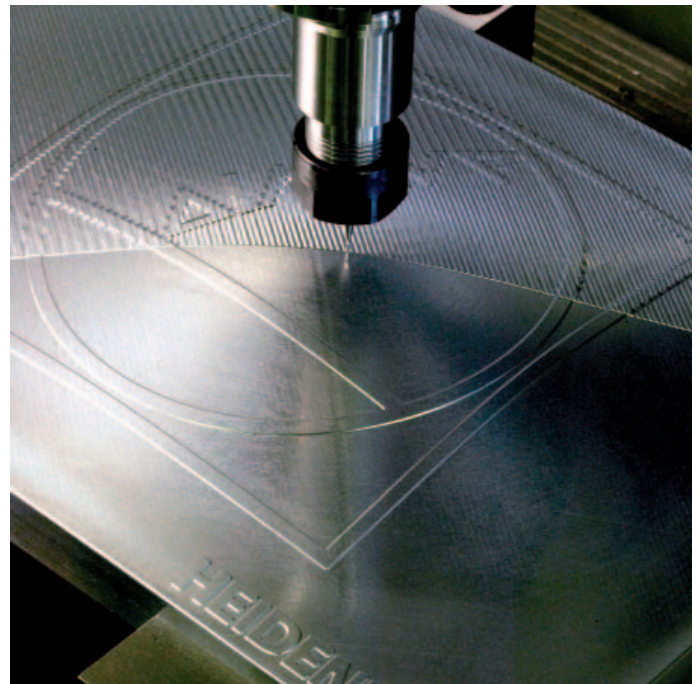
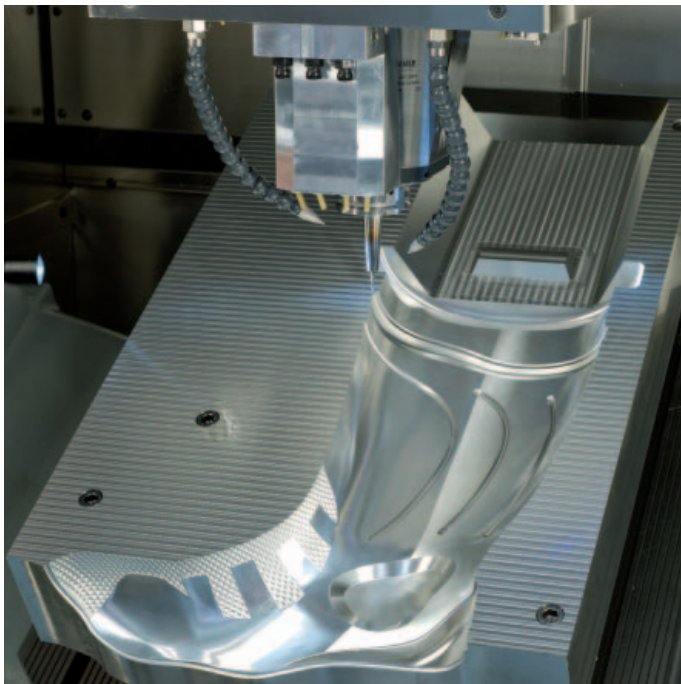

Fast machining and computing processes

The fast block-processing time of at most 0.5 ms enables the TNC 640 to run fast advance calculations in order to optimally use the dynamic parameters of the machine. In this way, functions like ADP and look-ahead not only provide very high contour accuracy and surface definition—they also optimize the machining time.

One of the reasons for the TNC 640's high speed is its **uniformly digital control design**. It consists on the one hand of the integrated digital drive technology from HEIDENHAIN, and on the other hand all control components are interconnected with digital interfaces—the control components via HSCI (HEIDENHAIN Serial Controller Interface), and the encoders via EnDat 2.2. This makes it possible to realize very high feed rates. And the TNC 640 interpolates simultaneously in up to five axes. To attain the required cutting speeds, the TNC 640 digitally controls spindle speeds up to **100 000 rpm**.

The TNC 640's powerful 5-axis machining enables you to manufacture even complex 3-D contours economically. The required programs are usually created on external CAM systems and comprise a large number of very short line segments that are transferred to the control. With its short block-processing time, the TNC 640 quickly executes even complex NC programs. Thanks to its computing power, however, it can also transfer complex advance calculations to simpler NC programs. This makes it unimportant what data volume the NC programs from their CAD systems have: with the TNC 640, the finished workpiece will be a virtually perfect reflection of the generated program.

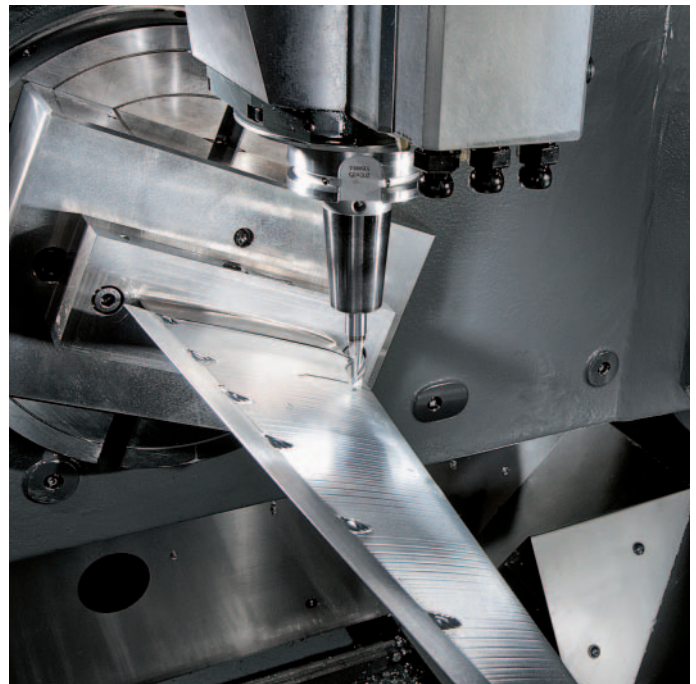

– Machining and measuring 3-D contours

Compensating tool form error

Option 92, **3D-ToolComp**, is a powerful option for three-dimensional tool radius compensation. A compensation-value table is used to define angle-dependent delta values that describe the tool deviation from the ideal circular form (see graphic).

The TNC 640 then corrects the radius value defined for the tool's current point of contact with the workpiece. In order to determine the point of contact exactly, the NC program must be created with surface-normal blocks (LN blocks) by a CAM system. The surface-normal blocks specify the theoretical center point of the tool, and in some cases also the tool orientation relative to the workpiece surface.

Ideally, the compensation-value table is generated fully automatically by way of a special cycle that uses a laser system to measure the form of the tool so that the TNC 640 can use this table directly. If the form errors of the tool used are available as a calibration chart from the tool manufacturer, then you can create the compensation-value table manually.

Measuring 3-D geometries

With Cycle 444, 3-D probing, you can measure points on 3-D geometries. You enter the respective measured point with its coordinates and the associated normal vectors into the cycle. After probing, the TNC automatically calculates whether the measured points are within a preset tolerance. You can interrogate the result through the system parameters in order, for example, to initiate program-controlled reworking. Moreover, you can trigger a program stop and a message. After measurement the cycle automatically generates an easy-to-read measuring log in HTML format.

To obtain even more accurate results, you can perform a 3-D calibration of the touch probe before running Cycle 444. Then the cycle compensates the touch probe's individual triggering behavior in any direction. Option 92 is required for 3-D calibration.

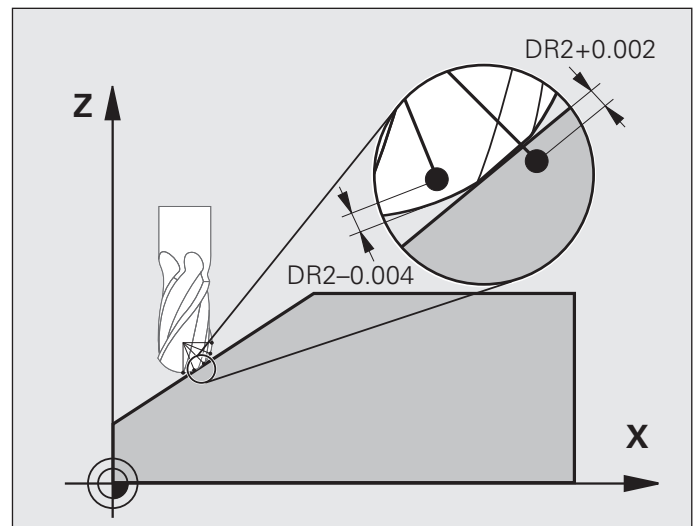

Machining with five axes

– Guided tool tip

CAM systems use postprocessors to generate 5-axis programs. In principle, such programs contain either all coordinates of the machine's existing NC axes, or NC blocks with surface normal vectors. During 5-axis machining with three linear axes and two additional tilting axes* the tool is always normal to the workpiece surface or is kept at a specific angle to it (inclined tool machining).

Regardless of what type of 5-axis programs you wish to run, the TNC 640 makes all the compensating movements in the linear axes that result from movements in the tilting axes. The TNC 640's **TCPM function** (Tool Center Point Management)—an improvement upon the proven TNC function M128—provides optimal tool guidance and prevents contour gouging.

* These functions must be implemented in the machine and TNC by the machine tool builder.

With TCPM you can define the behavior of the tilting and compensating movements automatically calculated by the TNC 640.

TCPM defines the **interpolation between the start and end positions:**

- During **face milling**, most of the cutting is by the face of the tool, or on toroidal cutters by the corner radius. The axes ensure that the tool point always stays on the programmed path.
- During **peripheral milling**, machining is mainly by the side of the tool. The tool tip also travels on the programmed path, but additionally the tool's circumference machines an explicitly defined plane. This suits peripheral milling for the manufacture of precise surfaces through hobbing.

TCPM defines the **effect of the programmed feed rate** as desired either

- as the actual velocity of the tool tip relative to the workpiece. Very high axis feed rates can result from large compensating motions during machining near the center of tilting, or
- as contouring feed rate of the axes programmed in the NC block. The feed rate is usually lower, but you attain better surface quality during large compensating movements.

With TCPM you can also define the **effect of the inclination angle** for more uniform cutting passes when working with an inclined radius cutter:

- Angle of inclination defined as axis angle
- Angle of inclination defined as spatial angle

The TNC takes the inclination angle into account in all 3-D machining—even with 45° swivel heads or tilting tables. You either specify the angle of inclination in the NC program via a miscellaneous function, or adjust it manually with an electronic handwheel. The TNC 640 makes sure that the tool remains on the contour and does not damage the workpiece.

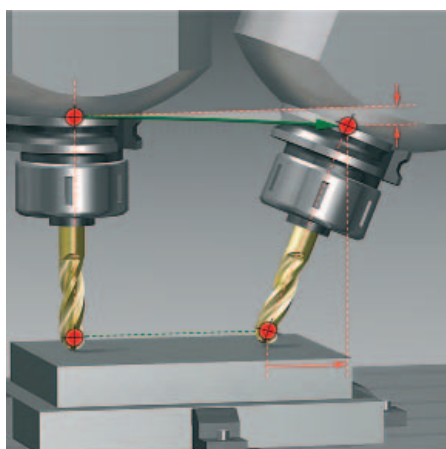

Face milling

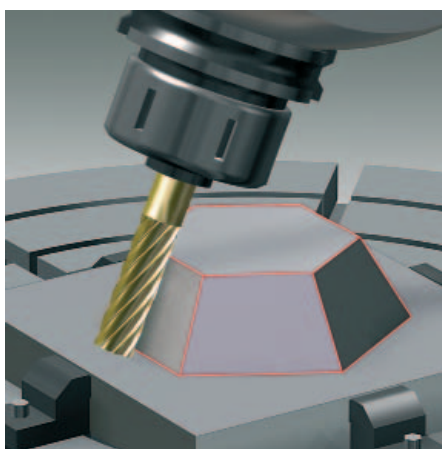

Peripheral milling

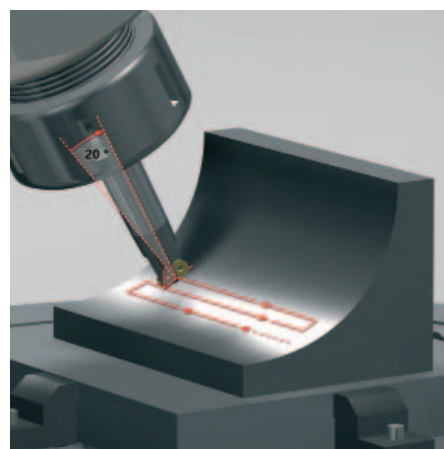

Inclined-tool machining

Machining with five axes

– Swivel head and rotary table controlled by the TNC

Many 5-axis operations that at first glance may seem very complex can be reduced to conventional 2-D movements that are simply tilted about one or more rotary axes or wrapped onto a cylindrical surface. The TNC supports you with application-oriented functions to help you write and edit such programs quickly and simply without a CAM system.

Tilting the working plane*

Programs for contours and holes on inclined surfaces are often very complex and require time-consuming computing and programming work. Here the TNC 640 helps you to save a great deal of programming time.

You program the machining operation as usual in the main plane, for example in X/Y. The machine then runs the program in a plane that has been tilted by one or more rotary axes with respect to the main plane.

The PLANE feature makes it easy to define a tilted working plane: you can specify tilted working planes in seven different ways, depending on the information on the workpiece drawing. Clearly arranged support graphics assist you during input.

You can also use the PLANE function to define the positioning behavior for tilting so that there are no unpleasant surprises when the program is run. The settings for defining the positioning behavior are identical for all PLANE functions, making everything that much easier.

* These functions must be implemented in the machine and TNC by the machine tool builder.

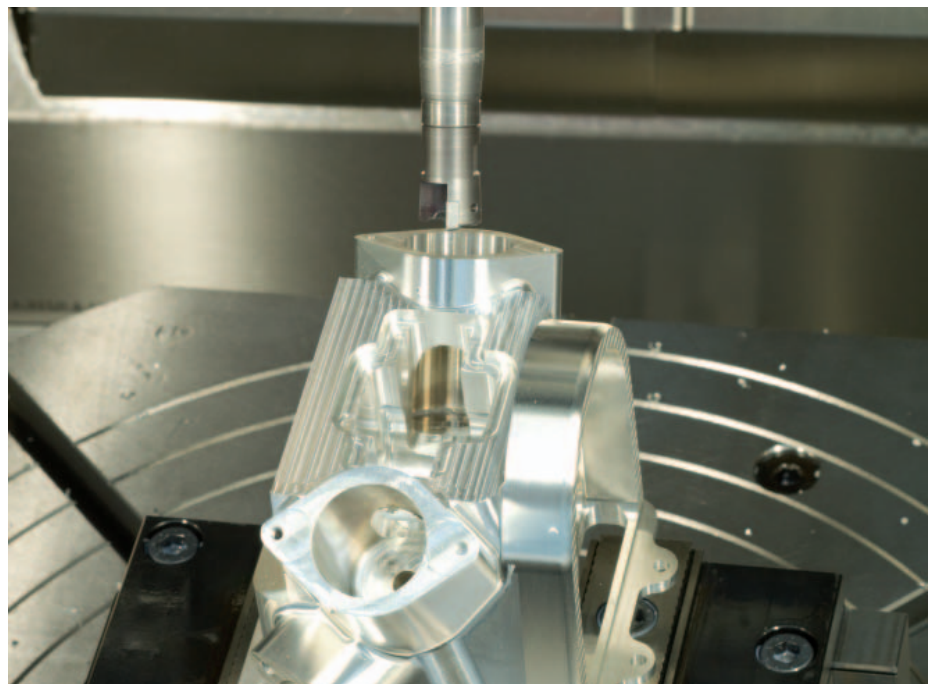

Cylinder surface machining*

With the TNC 640 it is quite easy to program contours (consisting of straight lines and arcs) on cylindrical surfaces using rotary and tilting tables: You simply program the contour in a plane as if the cylinder surface were unrolled. You enter a contour in two dimensions—as if in a plane—and the TNC 640 then calculates and machines the corresponding cylindrical contour.

The TNC 640 features four cycles for cylindrical surface machining:

- Slot milling (the slot width is the same as the tool diameter)
- Guide-groove milling (the slot width is greater than the tool diameter)
- Ridge milling
- Mill outside of contour

* These functions must be implemented in the machine and TNC by the machine tool builder.

Manual axis motion in the tool direction on 5-axis machines

The safe retraction of a tool is very important with five-axis machining. The “Virtual Tool Axis” function is of assistance here. You can use it to traverse the tool in the current direction of the tool axis through an external direction key or the handwheel. This function is especially useful if you want to

- retract the tool in the direction of the tool axis during interruption of a 5-axis machining program,
- use the handwheel or external direction keys to perform an operation in Manual mode with an inclined tool,
- move the tool with the handwheel in the active tool axis direction during machining.

Feed rate for rotary axes and tables in mm/min*

By default, the feed rate of rotary axes is programmed in degrees/minutes. However, the TNC 640 can interpret this feed rate in mm/min as well. The feed rate at the contour is then independent of the distance of the tool center from the center of the rotary axis.



Intelligent machining

– Dynamic Collision Monitoring option (DCM)

The complex motions and the normally high traversing speeds of 5-axis machining make axis movements difficult to foresee. This makes collision monitoring a valuable function that relieves the machine operator and protects the machine from damage.

NC programs from CAM systems may avoid collisions of the tool or tool holder with the workpiece, but unless you invest in expensive offline machine simulation software, they ignore the machine components located within the work envelope. And even then it cannot be guaranteed that machine conditions, such as the fixture position, will be identical to those of the simulation. In the worst case, a collision will remain undetected until the damage is done.

In cases such as these, the machine operator is supported by the **dynamic collision monitoring (DCM)*** feature of the TNC 640. The control interrupts machining whenever a collision is imminent, thereby increasing the safety for the machine and its operator. This helps to prevent machine damage, which can result in costly downtimes. Unattended shifts become safer and more reliable.

However, DCM works not only in **automatic mode**. It is also active in **manual operation**. If, for example, during setup the machine operator takes a collision course, the TNC 640 detects it, stops axis movement, and issues an error message.

* These functions must be implemented in the machine and TNC by the machine tool builder.

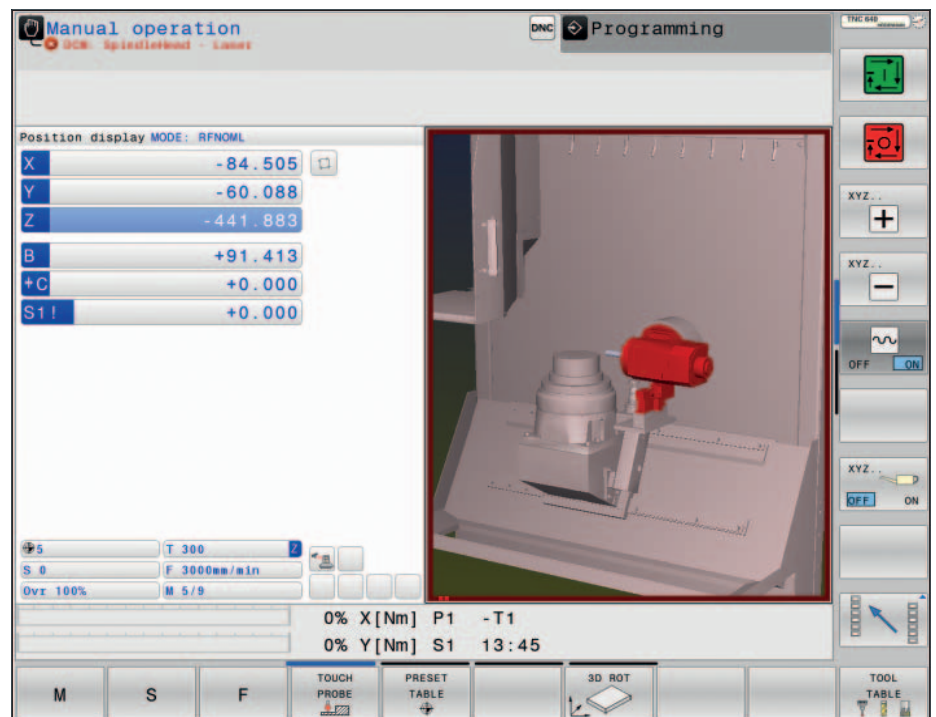

Of course the TNC 640 also shows the machine operator—both with an error message and graphically—which machine components are endangered. If a collision warning is displayed, the TNC permits retracting the tool only in those directions which increase the clearance between the colliding objects.

The machine tool builder takes care of the required definition of **machine components**. The working space and the collision objects are described using geometric bodies. For tilting devices, the machine tool builder can also use the description of the machine kinematics to define the collision objects.

A new 3-D format for collision objects offers further appealing benefits:

- Simple data transfer of standard 3-D formats
- Fully detailed illustration of machine components
- Greater exploitation of the working space

The TNC 640 can also monitor tool carriers such as holders for milling cutters or touch probe housings. A tool-carrier kinematic model is assigned to the tool in the tool table. When the tool is changed, the respective tool carrier is activated.

Because the machine design in itself prevents collisions between certain machine components, they can be ruled out from the start. For example, a tool touch probe like the HEIDENHAIN TT

clamped on the machine table can never come into contact with the machine cabin. The machine tool builder can therefore specify which collisions between machine elements even come into question.

When using the dynamic collision monitoring, please note:

- DCM can help to reduce the danger of collision. DCM cannot completely prevent all collisions.
- Only the machine manufacturer can define machine components.
- Collisions between machine components (such as swivel heads) and the workpiece cannot be detected.
- DCM cannot be used during operation in following error mode (i.e. without feedforward).
- DCM cannot be used for eccentric turning.

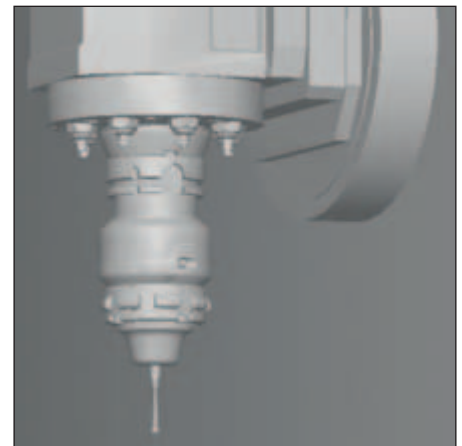
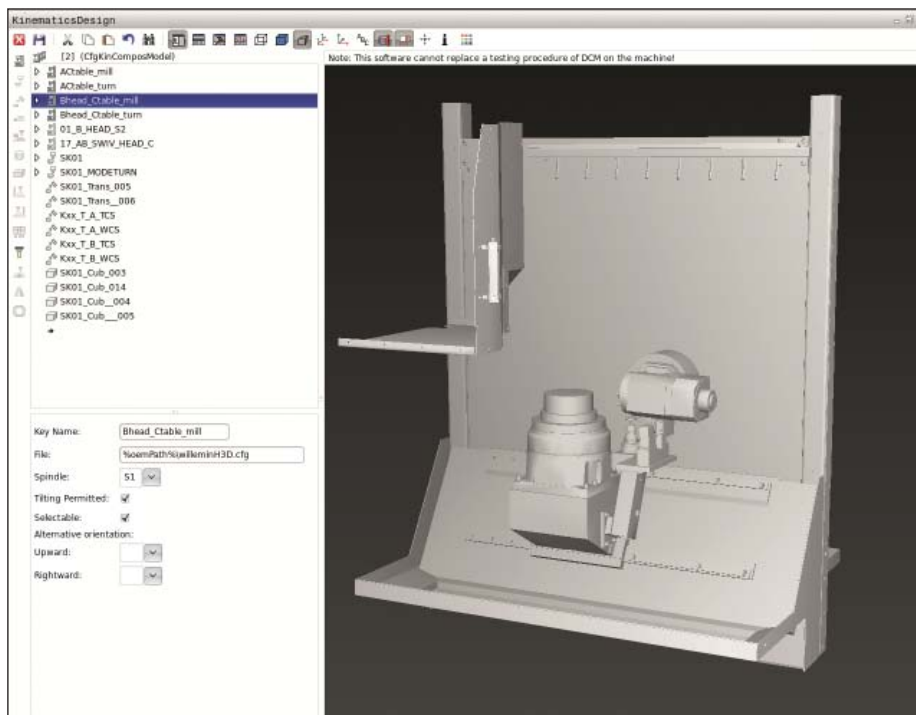

Intelligent machining

– Dynamic Efficiency

dynamic + efficiency

With the concept of **Dynamic Efficiency**, HEIDENHAIN offers innovative TNC functions that help the user to make heavy machining and roughing more efficient while also enhancing its process reliability. The software functions support the machine operator but also make the manufacturing process itself faster, more stable and more predictable—in short, more efficient. Dynamic Efficiency permits higher removal rates and therefore increases productivity without making the user resort to special tools. At the same time, it prevents any tool overloading and the concomitant premature cutter wear. All of this means that with Dynamic Efficiency you can manufacture more economically while increasing process reliability.

Dynamic Efficiency comprises three software TNC functions:

- **Active Chatter Control (ACC)** – The ACC option reduces chatter tendencies and permits greater infeeds
- **Adaptive Feed Control (AFC)** – The AFC option controls the feed rate depending on the machining situation
- **Trochoidal milling** – A function for the roughing of slots and pockets that eases the load on the tool and the machine

Each solution in itself offers decisive advantages in the machining process. But the combination of these TNC features, in particular, exploits the potential of the machine and tool and at the same time reduces the mechanical load. Changing machining conditions, such as interrupted cuts, various material plunging procedures, or simple clear-out also show that these features pay for themselves. In practice, removal rate increases of 20 to 25 percent are possible.

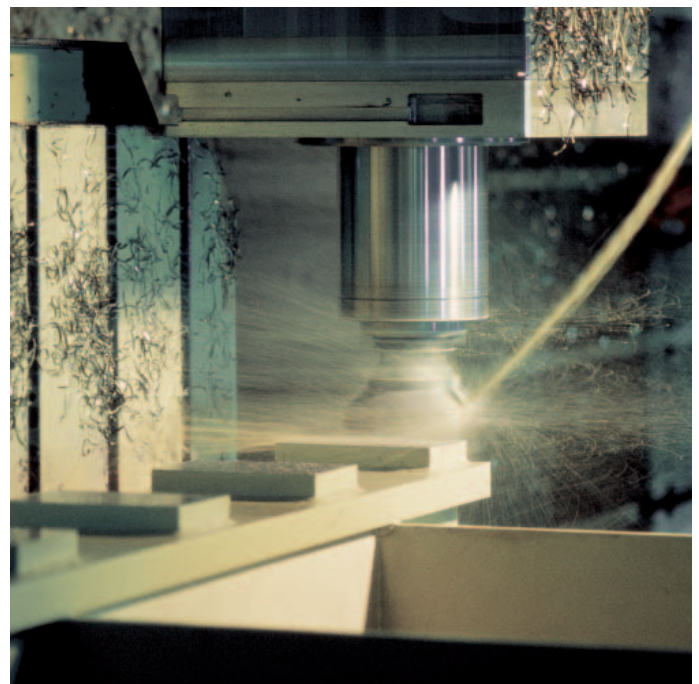

– Active Chatter Control option (ACC)

dynamic  efficiency

Strong forces come into play during roughing (power milling). Depending on the tool spindle speed, the resonances in the machine tool and the chip volume (metal-removal rate during milling), the tool can sometimes begin to “chatter.” This chattering places heavy strain on the machine, and causes ugly marks on the workpiece surface. The tool, too, is subject to heavy and irregular wear from chattering. In extreme cases it can result in tool breakage.

To reduce the inclination to chatter, HEIDENHAIN now offers an effective control function with its Active Chatter Control option (ACC). The use of this control function is particularly advantageous during heavy cutting:

- Better cutting performance
- Higher metal removal rate (up to 25 % and more)
- Lower forces on the tool, thereby increasing service life
- Smaller load on the machine



Heavy machining without ACC (upper image) and with ACC (lower image)



Intelligent machining

– Adaptive Feed Control option (AFC)

dynamic + efficiency

Besides the feed rate for each block or cycle, HEIDENHAIN controls have always allowed the programmer to enter a manual compensation through the override potentiometer to adjust for the actual machining situation. But this always depends on the experience and, of course, the presence of the operator.

Adaptive Feed Control (AFC) automatically regulates the feed rate of the TNC, taking into consideration the respective spindle power and other process data. In a teach-in cut, the TNC records the maximum spindle power. Then, before actual machining, you define in a table the respective limit values between which the TNC can influence the feed rate in the "control" mode. Of course, various overload reactions can be provided for, which can also be defined by your machine tool builder.

Adaptive feed rate control offers various advantages:

Process reliability

Roughing with high metal removal rates requires strong cutting forces. In practice this often causes tool defects. If the user doesn't react quickly enough, for example because he is responsible for several machine simultaneously, or if the shift is unattended, this can result in serious subsequent damage and high costs:

- Costly rework on the workpiece
- Irreparable workpiece damage
- Damage to the tool holder
- Machine downtime due to spindle damage

An increase in spindle power consumption due to tool wear or defective inserts is detected by continuous monitoring, and a sister tool can be automatically inserted.* In this way, AFC effectively avoids possible damage from tool wear and therefore increases process safety and reliability.

Reduction of machining time

AFC regulates the feed rate of the TNC, taking into consideration the respective spindle power. In zones with less material removal, the feed rate is increased accordingly. This can significantly reduce the machining time.

Protection of the machine mechanics

Reducing the feed rate down to the reference value whenever the learned maximum permissible spindle power is exceeded also reduces the strain and wear on the machine. It effectively protects the spindle from overload.

*The machine must be prepared by the machine tool builder for this function.

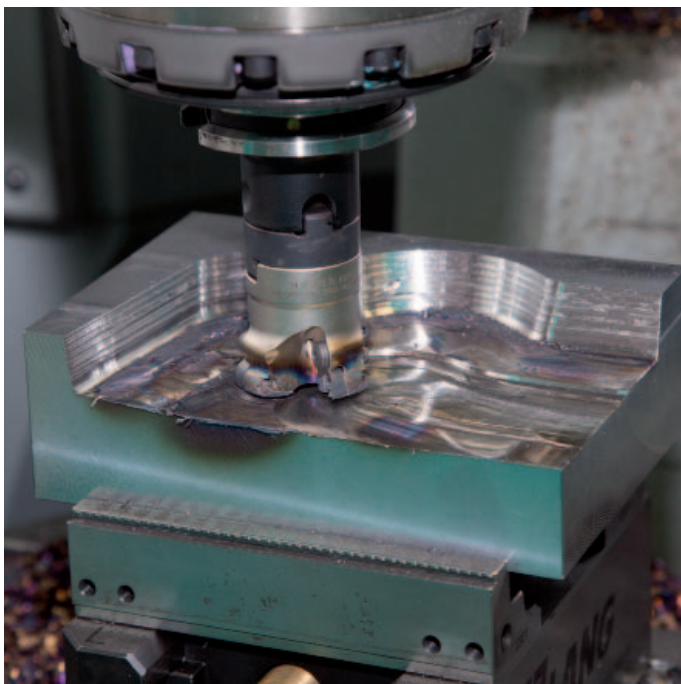

Workpiece with damage resulting from a broken indexable insert

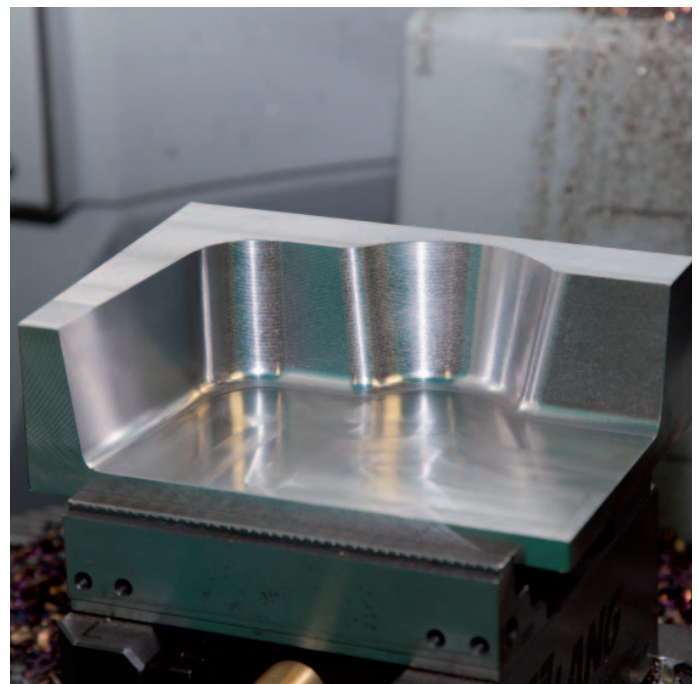

Fully machined workpiece protected by AFC

– Machining any contour slots with trochoidal milling

dynamic + efficiency

The benefit of trochoidal milling is its ultra-efficient machining of slots of all kinds. The roughing process is a circular motion superimposed on a forward linear motion. This procedure is referred to as trochoidal milling. It is used particularly for milling high-strength or hardened materials, where the high loads placed on the tool and machine usually only permit small infeeds.

With trochoidal milling, on the other hand, large cutting depths are possible since the prevailing cutting conditions do not increase the wear and tear on the tool. On the contrary, the entire length of a hob's cutting edges can be used. This enables you to achieve a greater chip volume per tooth. Circular plunging into the material places less radial force on the tool. This reduces the mechanical load on the machine and prevents vibration. Enormous time savings can be realized by combining this milling method with the integrated Adaptive Feed Control (AFC) option.

The slot to be machined is described in a contour subprogram as a contour train. You define the dimensions of the slot and the cutting data in a separate cycle. Any residual material remaining can then easily be removed with a subsequent finishing cut.

The benefits include:

- Engagement of the entire cutter length
- Higher metal removal rates
- Relieves mechanical load on the machine
- Less vibration
- Integrated finishing of the side wall
- Better chip removal

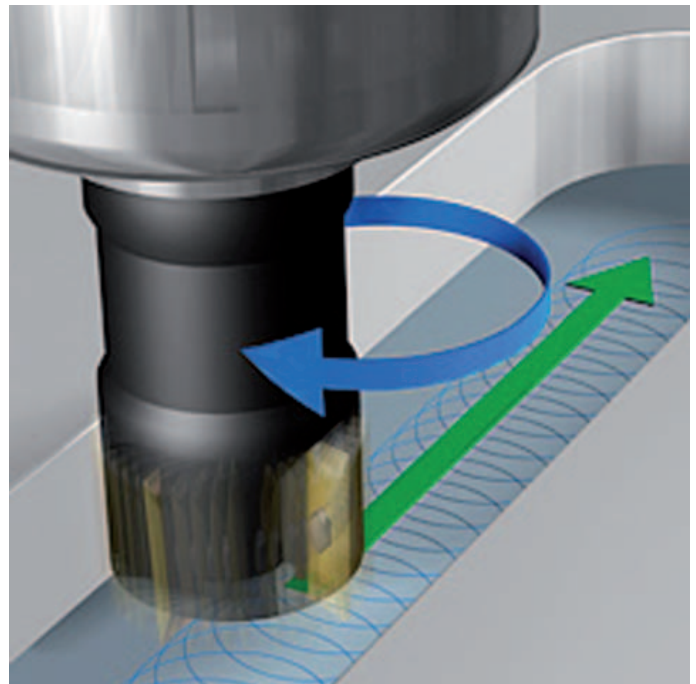

Minimize setup times

– The TNC 640 makes setup easy

Before you can begin machining, you must first clamp the workpiece and set up the machine, find the position and orientation of the workpiece on the machine, and set the workpiece reference point. This is a time-consuming but indispensable procedure. After all, any error directly reduces the machining accuracy. Particularly in small and medium-sized production runs, as well as for very large workpieces, setup times become quite a significant factor.

The TNC 640 features application-oriented, real-world setup functions. They support the user, help to reduce non-productive time, and make overnight, unattended production possible. Together with the **touch probes**, the TNC 640 offers numerous probing cycles for automatic alignment of the workpieces, presetting, and measurement of the workpiece and the tool.

Delicate manual traverse

For setup, you can use the direction keys to move the machine axes manually or in incremental jog. A simpler and more reliable way, however, is to use the electronic handwheels from HEIDENHAIN (see page 48). With the handwheels you are always close to the action, enjoy a close-up view of the setup process, and can control the infeed responsively and precisely.

Adapting the probing velocity

Frequently, the workpiece has to be probed at hidden locations or in cramped spaces. In this case, the standard probing feed rate is usually too fast. In such situations you can use the override knob to change the feed rate during probing. What is special about this option is that it does not influence accuracy.

Workpiece alignment

With HEIDENHAIN touch probes (see page 45) and the probing functions of the TNC 640, you can forgo any tedious manual alignment of the workpiece:

- Clamp the workpiece in any position.
- The touch probe ascertains the workpiece misalignment by probing a surface.
- The TNC 640 compensates the misalignment with a “basic rotation,” which means that in the NC program the part is rotated by the measured misalignment, or the rotary table itself is turned to correct the misalignment.

Compensating workpiece misalignment

Compensate misalignment by rotating the coordinate system or turning the table

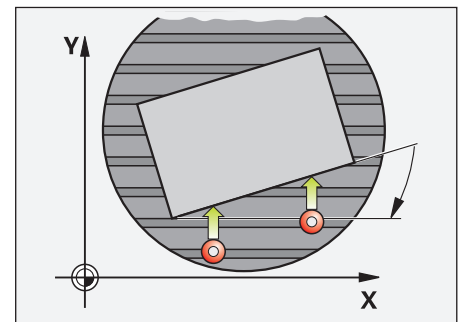
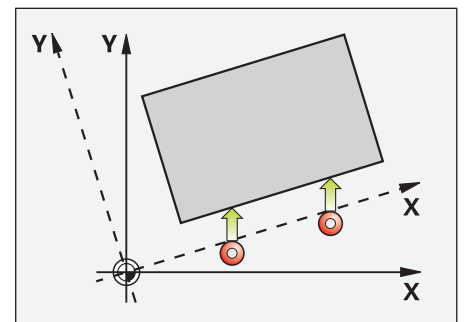

Setting reference points

You can use a reference point to assign a defined value in the TNC display to any workpiece position. Finding this point quickly and reliably reduces nonproductive time and increases machining accuracy. The TNC 640 features probing cycles for automatic presetting. Once found, you can save these points

- in the reference-point manager,
- in a datum table, or
- by directly setting the displayed value.

Setting a reference point

At a corner, for example, or in the center of a circular stud

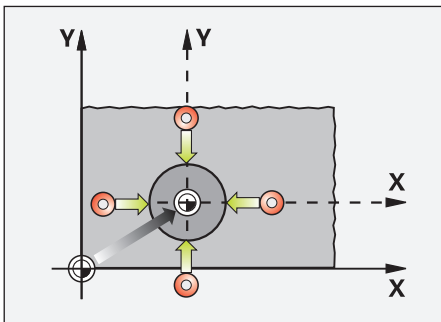
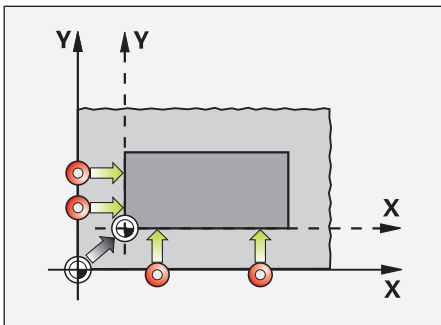

Managing reference points with the preset table

The reference-point manager makes flexible machining, shorter setup times and increased productivity possible. In other words, it makes it much easier to set up the machine.

In the reference-point manager you can save **any number of reference points** and assign an individual basic rotation to each one. To permanently save fixed reference points in the machine working space, you can also write-protect individual lines.

There are three possibilities for rapid saving of the reference points:

- In the Manual mode by soft key
- By using the probing functions
- With the automatic probing cycles

Saving datums

In datum tables, you can save positions or values given measured with respect to the workpiece. Datums are always relative to the active reference point.

NO	DOC	X	Y	Z	SPC
0					
1	WP-1	-122.498	-355.443	-374.871	0
2	WP-2	-286.332	-355.365	-374.843	0
3	WP-3	-360.221	-355.405	-374.892	0
4		0	0	0	0
5	CENTER	-234.445	-304.002	0	0
6		0	0	0	0
7		0	0	0	0
8		0	0	0	0
9		0	0	0	0

DOC: Text width 16 TNC:\table\preset.pr

X: -91.140 A +0.000
 Y: +138.127 C +0.000
 Z: -10.000

Mode: NOML T: WP-1 T: 5 S: 2000 F: 0mm/min Ovi: 100% M: 5/9

Buttons: CHANGE PRESET, BASE TRANSFORM. OFFSET, ACTIVATE PRESET, END

Automated machining

– The TNC 640 measures, manages and communicates

The difference in requirements placed on the classical machine for tool and mold-making and machining centers is becoming ever less distinct. Of course, the TNC 640 is capable of controlling automated manufacturing processes. It masters the range of functions needed to start the proper machining operations on individual workpieces in any setup, and even in interlinked machining.

Inspecting workpieces for proper machining and dimensional accuracy

The TNC 640 features a number of measuring cycles for checking the geometry of the machined workpieces. For the measuring cycles you insert a touch probe from HEIDENHAIN (see page 45) into the spindle in place of a tool. This enables you to

- recognize a workpiece and call the appropriate part program,
- check whether all machining operations were conducted correctly,
- determine infeeds for finishing,
- detect and compensate tool wear,
- check the workpiece geometry and sort the parts,
- log measured data,
- ascertain the machining error trend.

Milling cutter measurement and automatic compensation of tool data

Together with the TT and TL for tool measurement (see page 46), the TNC 640 makes it possible to measure milling cutters automatically while they are in the machine spindle. The TNC 640 saves the ascertained values of tool length and radius in the central tool file. By inspecting the tool during machining you can quickly and directly measure wear or breakage to prevent scrap or rework. If the measured deviations lie outside the tolerances, or if the monitored life of the tool is exceeded, the TNC 640 locks the tool and automatically inserts a replacement tool.

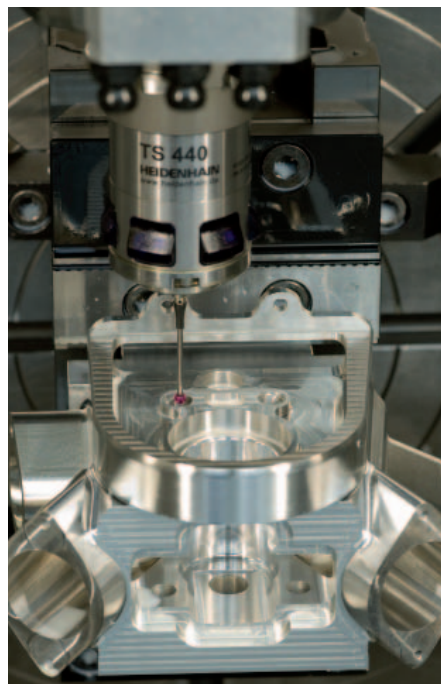

Tool management

For machining centers with automatic tool changers, the TNC 640 offers a central tool memory for any number of milling and turning tools. The tool memory is a freely configurable file and can therefore be optimally fitted to your needs. You can even have the TNC 640 manage your tool names. The control prepares the next tool change while the current tool is still cutting. This significantly reduces the non-cutting time required for changing tools.

With the optionally available expanded tool management you can also graphically prepare and display any data.*

* The machine must be prepared by the machine tool builder for this function.

Pallet management

The TNC 640 can assign the appropriate part program and datum shift to parts mounted on pallets and brought to the machine in any sequence. If a pallet is exchanged, the TNC 640 automatically calls the correct part program. This permits automatic machining of a variety of parts in any sequence.

Monitoring of the working space

With the Visual Setup Control option (VSC), the TNC can automatically monitor the current setup or machining situation during program run. With this option, reference photos are taken by a camera system for the first parts of a series, which are then compared with the photos of the subsequent parts.

User friendly cycles enable you to specify several places in the NC program at which the control conducts an optical comparison of the actual with the desired condition. If an error is detected, the TNC reacts as previously chosen by the user.

VSC not only helps you to avoid expensive damage to the tool, workpiece and machine, it also enables you to recognize missing operations or to document repetitive setup situations.

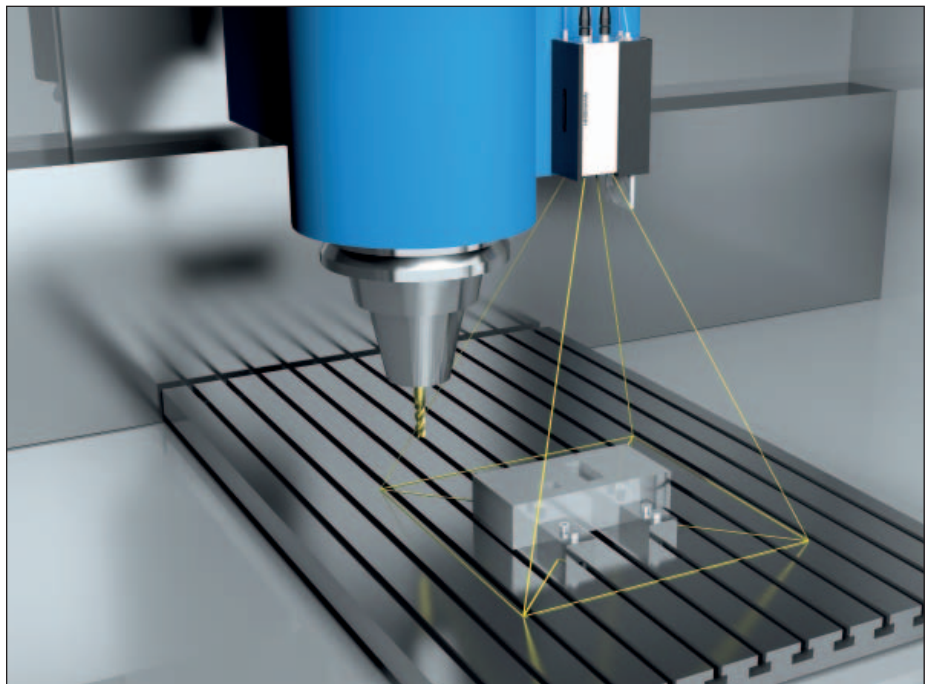

Programming, editing, testing

– The TNC 640 opens endless possibilities

The TNC 640 is just as universal in application as it is flexible in machining and programming.

Positioning with Manual Data Input

You can start working with the TNC 640 even before writing a complete part program. Simply machine a part step by step—switching as you want between manual operation and automatic positioning.

Programming at the machine

HEIDENHAIN controls are workshop oriented, which means that they were conceived for programming right at the machine. With Klartext conversational programming you can forget about memorizing G codes. Instead you use dedicated keys and soft keys to program line segments, circular arcs and cycles. You initiate a HEIDENHAIN Klartext dialog with a keystroke and the TNC immediately begins to support you actively in your work. Unambiguous questions and prompts help you enter all the required information.

Whether Klartext prompts, dialog guidance, programming steps, or soft keys, all texts are available in numerous languages.

Even if you are used to **G-code programming**, however, the TNC is still the right control—you can enter G-code commands over soft keys or directly through the alphanumeric keyboard.

Creating programs offline

The TNC 640 is also well equipped for offline programming. Through its interfaces it can be integrated into networks and connected with programming stations or other data storage devices.



– Graphic support in any situation

Programming graphics

The two-dimensional programming graphics give you additional security: while you are programming, the TNC 640 draws every entered traverse command on the screen. You can select among plan view, side view, and front view. Also, tool paths and rapid-traverse movements can be hidden and the view can be scaled.

Test graphics

To play it safe before running a program, the TNC 640 can simulate the machining of the workpiece, and can show this with high-resolution graphics. The TNC 640 can present different views of the simulation:

- As a plan view with different shades of depth
- In three projections
- As a solid model, 3-D view

You can adjust the type and quality of the image. Details can be displayed in magnification. In addition, the TNC 640 indicates the calculated machining time in hours, minutes and seconds.

In the 3-D view, you can display the programmed tool-center path in three dimensions. With the powerful zoom function you can also see the finest details. You should especially use the 3-D line graphics to inspect programs created offline for irregularities before machining, in order to avoid undesirable traces of the machining process on the workpiece, e.g. when points are output incorrectly by the postprocessor. The TNC also features a measuring function in the 3-D view. You can position the mouse pointer anywhere in the graphic to see the coordinates.

Program-run graphics

The program-run graphics display the workpiece in real time to show you the current stage of machining. Direct workpiece observation is usually impossible due to the coolant and the safety enclosure. During workpiece machining, you can switch at any time between various operating modes, for example to create programs. You then use free moments for a keystroke to take a glance at the progress of workpiece machining.

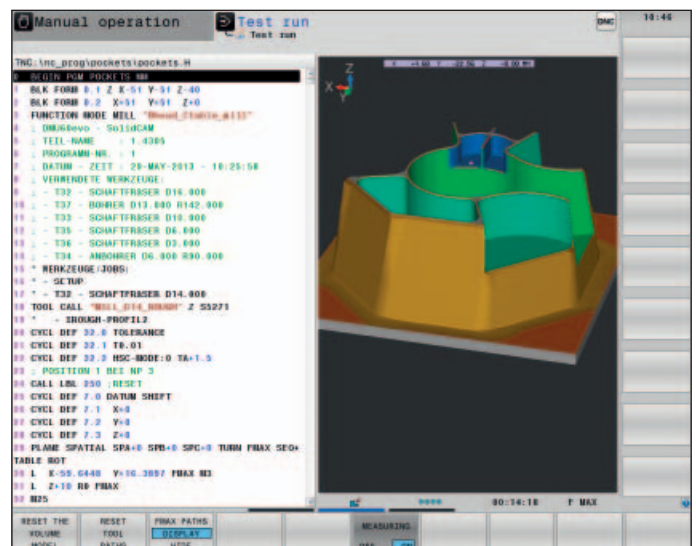
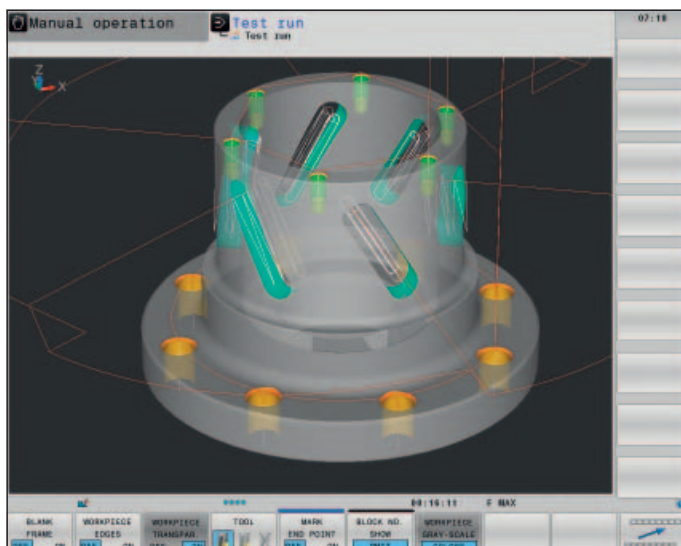

Programming in the workshop

– Straightforward function keys for complex contours

Programming 2-D contours

Two-dimensional contours are the bread and butter of the modern machine shop. The TNC 640 offers a variety of possibilities here. And—regardless of whether you are programming a milling or turning contour—you always use the same tools. For you this means that you do not have to relearn, just continue to program as usual.

Programming with path function keys

If contours are dimensioned for NC, which means that the end points are specified in Cartesian or polar coordinates, then you can program them directly with the path function keys.

Straight and circular contour elements

To program a line segment, for example, simply press the key for linear traverse. The TNC 640 asks in Klartext format for all information required for a complete programming block, such as target coordinates, feed rate, tool compensation, and machine functions. Appropriate path function keys for circular movement, chamfers, and corner rounding simplify your programming. To avoid surface blemishes during approach or departure from the contour, movement has to be smooth—that is, tangential.

You simply specify the starting or end point of the contour and the approaching or departing radius of the cutter edge—the control does the rest for you.

The TNC 640 can look ahead over a radius-compensated contour for up to 99 blocks to watch for back cutting and avoid contour damage such as can occur when roughing a contour with a large tool.

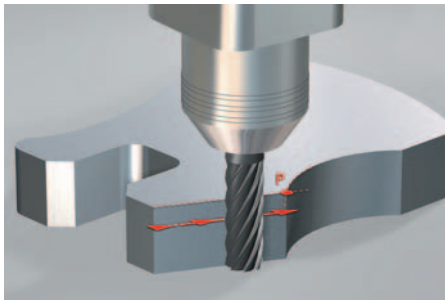

L Straight line defined by its end point

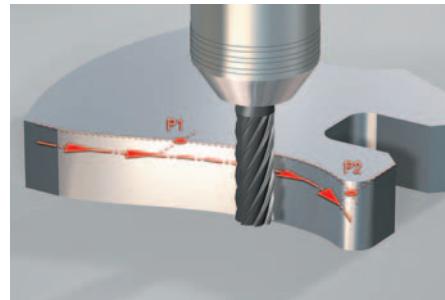

CT Circular path with smooth (tangential) connection with the preceding contour element, defined by end point

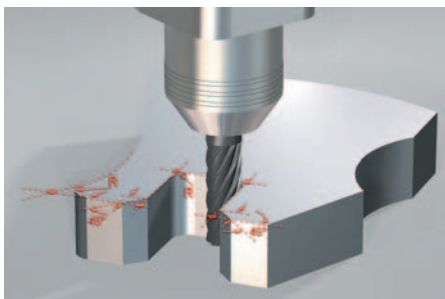

RND Corner rounding: circular path with smooth (tangential) connection on both sides, defined by radius and corner point

CHF Chamfer defined by the corner point and chamfer length

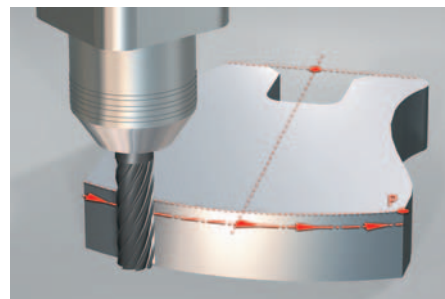

CC + C Circular path defined by its center, end point, and rotational direction

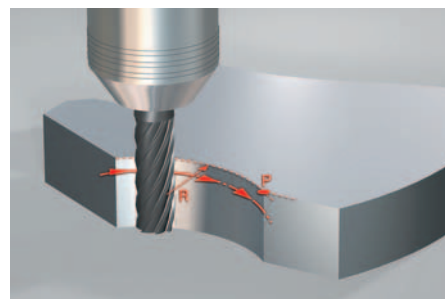

CR Circular path defined by its radius, end point and rotational direction

– Programming contours unconventionally

FK free contour programming

Not all workpieces are dimensioned for conventional NC programming. Thanks to FK, the control's free contour programming feature, in such cases you simply type in the known data—without first having to convert or calculate your data! It does not matter if individual contour elements are not completely defined as long as the complete contour has been. If the given data result in more than one mathematical solution, the helpful TNC 640 programming graphics show you the possible variants for your selection.

Lathe-specific contour elements (option)

The TNC 640 provides special contour elements to enable you to define recesses and undercuts. Axial or radial recesses can be defined over the GRV (groove) function. With the aid of dialog guidance and help graphics, you use the proper parameters to define the desired recess.

Undercuts can be defined using the UDC function. Here the forms E, F, H, K and U are available as well as thread undercuts.

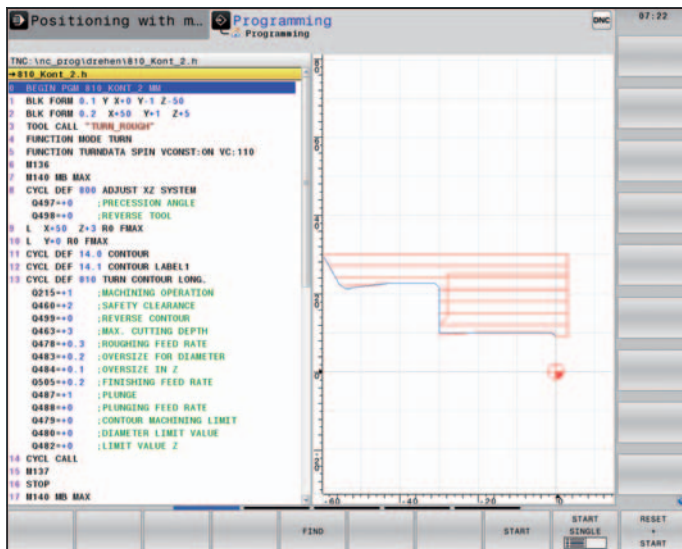

Programming in the workshop

– Field-proven cycles for recurring operations

Comprehensive fixed cycles for milling, drilling and boring

Frequently recurring operations that comprise several working steps are stored in the TNC 640 memory as standard cycles. You program them under conversational guidance and are supported by graphics that clearly illustrate the required input parameters.

Standard cycles

Besides the fixed cycles for drilling and tapping (with or without floating tap holder), there are optional cycles for thread milling, reaming, engraving, and boring, as well as for hole patterns, for clearing plane surfaces, and for roughing and finishing pockets, slots and studs.

Cycles for complex contours

The **Subcontour List cycles** (SL) are particularly helpful for clearing pockets with combined contours. This term is used to identify machining cycles for pilot drilling, roughing and finishing when the contour or subcontours are specified in subroutines. In this way, one contour description can be used for more than one operation using different tools.

Up to twelve **subcontours** can be superimposed for machining. The control automatically calculates the resulting contour and the tool paths for roughing or clearing the surfaces. Subcontours can be pockets or islands. Different components are combined to form a single pocket in which the tool avoids the islands.

The TNC 640 maintains a **finishing allowance** on the wall and floor surfaces during roughing. When **roughing** with different tools, the control identifies material remaining in inside corners so that it can be cleared later with smaller tools. A separate cycle is used for milling to the finished dimension.

OEM cycles

As original equipment manufacturers (OEMs), machine-tool builders can contribute their special manufacturing know-how by designing additional fixed cycles and saving them in the TNC 640. However, the end user can write his own cycles as well. HEIDENHAIN makes this possible with its PC program CycleDesign. This enables you to organize the input parameters and soft-key structure of the TNC 640 to suit your own needs.



Simple and flexible programming of machining patterns

Machining positions are often arranged in patterns on the workpiece. With the TNC 640, you can program very diverse machining patterns simply and extremely flexibly—of course with graphic support. You can define as many point patterns as desired with various numbers of points. Then you can execute all points at once or each point individually.

3-D machining with parametric programming

With parameter functions you can program simple 3-D geometric figures that can easily be described mathematically. Here you can use the basic arithmetical operations, trigonometric functions, roots, powers, logarithmic functions, parentheses, and logical comparisons with conditional jump instructions. Parametric programming also offers you a simple method of realizing 3-D operations. Of course, parametric programming is also suited for **2-D contours** that cannot be described with line segments or circular arcs, but rather through mathematical functions.

Hobbing of external teeth*

With Cycle 880 Gear Hobbing you can machine external cylindrical gears or helical gears with any angles. During hobbing, the rotation of the tool spindle and that of the rotary table are synchronized. In addition, the gear hob moves along the workpiece in axial direction. The new Cycle 880 automatically controls these complex movements and enables you to enter all relevant values easily and practically. You can use the tooth parameters directly from your drawing—the cycle calculates from them the course of five-axis movement.

* Software options 50 and 131 required



Programming in the workshop

– Field-proven turning cycles (option)

In the area of milling cycles, too, the TNC 640 offers a comprehensive and technologically ambitious package. They are equivalent to the proven and fully developed core functions of the HEIDENHAIN lathe controls. The user interface, however, is inspired in its look and functionality by the familiar and proven Klartext plain-language format. Cycle parameters that come into use both for milling and turning are, of course, used with the same number. For turning operations, as well, you are supported during programming as accustomed with explanatory graphics.

Machining simple contours

Various cycles are available for machining simple contours in longitudinal and transverse direction. The surface to be machined might also be inclined and can require a plunging movement. Naturally, the TNC 640 fully automatically takes the angle of the turning tool into account.

Machining any desired contours

If the contours to be machined become more complex and can no longer be defined with simple cycle parameters, you can describe them using contour subprograms. The process is completely identical to the procedure when using SL cycles in milling: with Cycle 14 you define the subprogram in which the finished contour is described, and in the respective turning cycle you specify the technological parameters.

During contour description, too, you use exactly the same Klartext functions as when defining a milling contour, which of course includes FK free contour programming. Moreover, the turning-specific contours elements recess and undercut are available, which you can insert between contour elements like chamfers and rounding arcs. Besides radial and axis recesses, undercuts of the forms E, F, H, K, U are available, as are thread undercuts.

Depending on the cycle, the TNC 640 machines parallel to the axis or the contour. You define the machining operations (roughing, finishing) or oversize under dialog guidance through the corresponding parameters.

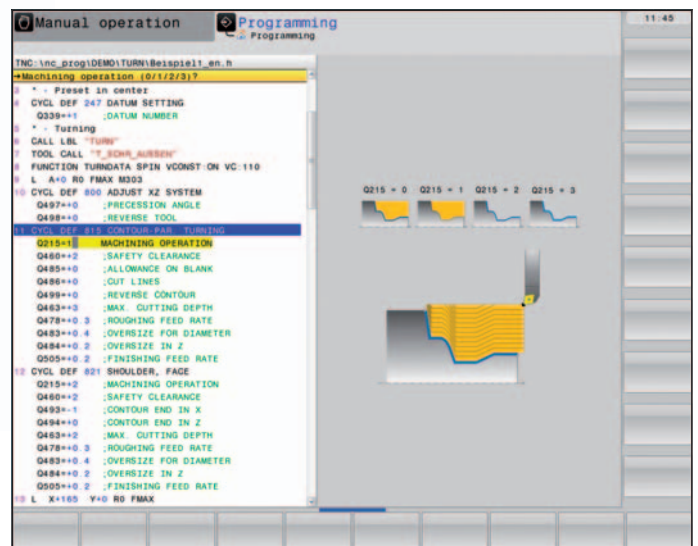
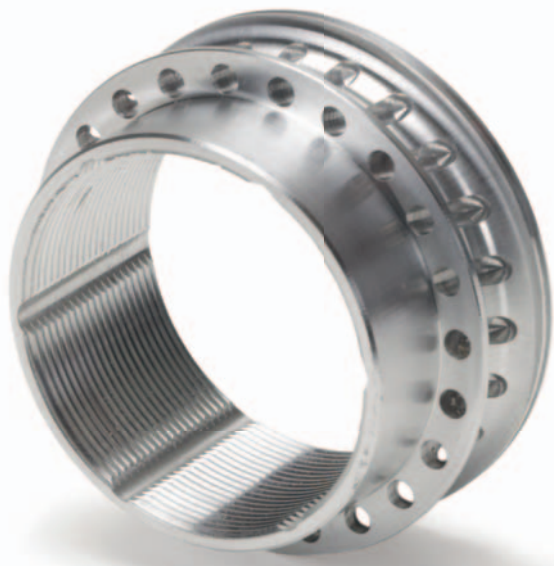

Recessing

In this area, as well, the TNC 640 distinguishes itself with ample flexibility and functionality. Simple recessing operations in longitudinal and transverse direction are just as possible as contour recessing, in which the cycle is machined along any desired contour. You can work particularly effectively during recess turning. Because infeed and cutting alternate directly, air cuts are hardly necessary. Here, too, the TNC considers the technological constraints (width of recessing tool from the tool table) and executes the operations quickly and reliably.

Thread machining

Simple and expanded cycles are available for longitudinal and transverse machining of cylindrical or tapered threads. You can use cycle parameters to define the manner in which the thread is produced. This enables you to machine a wide variety of materials.

Blank form update

Another highlight of the TNC 640 is the blank form update feature. If you define the workpiece blank at the beginning of your program, the control then computes the new blank for each following step. The machining cycles always adapt to the current workpiece blank. The blank form update feature helps you to avoid air cuts and optimize approach paths.

Orientation of the turning tool

On milling/turning machines it can be necessary to incline the tool during turning or change the side from which the part is to be machined. With the aid of a cycle, the TNC can change the tool's angle of incidence or use an outside turning tool as an inside tool without having to adjust the tool tip and/or the angle of orientation in the tool table.

Eccentric turning (option)

With the eccentric turning function you can perform turning operations even when the workpiece axis, due to the setup situation, is not aligned with the axis of rotation. During machining, the TNC 640 compensates any eccentricity with opposing movements of the linear axis coupled with the rotating spindle.

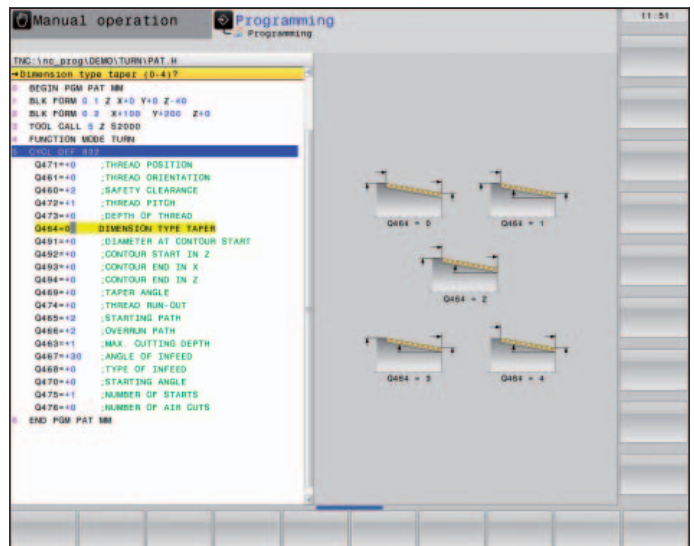
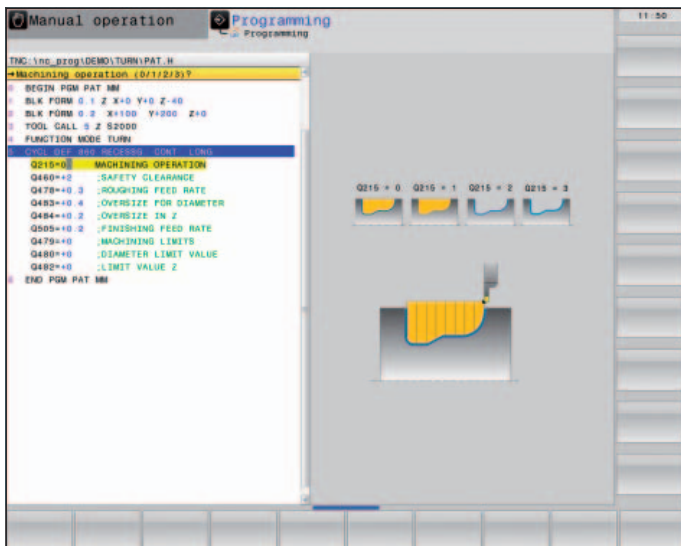

Programming in the workshop

– Reusing programmed contour elements

Coordinate transformation

If you should need a contour that has already been programmed at another position or in a different size, the TNC 640 offers you a simple solution: coordinate transformation.

Depending on the machining task, you can **rotate** (milling) and/or **mirror** (milling) the coordinate system, as well as **shift the datum** (milling and turning). With a **scaling factor** (milling) you can enlarge or reduce contours to respect shrinkage or oversizes.

Program section repeats and subprograms

Many machining operations repeat themselves either on the same workpiece or on different workpieces. Once you have programmed a detail, there is no reason to have to program it again. With its sub-programming feature, the TNC can save you a great deal of programming time.

In **program section repeats**, you label a section of the program and during program run the TNC repeats the section successively as many times as required.

You can mark a program section as a **subprogram** and then call it at any point in the program and as often as you want.

With the **program call** function you can even use a completely separate program at any place in your current program. This gives you convenient access to pre-programmed, frequently needed working steps or contours.

Of course you can also combine these programming techniques as often as desired.

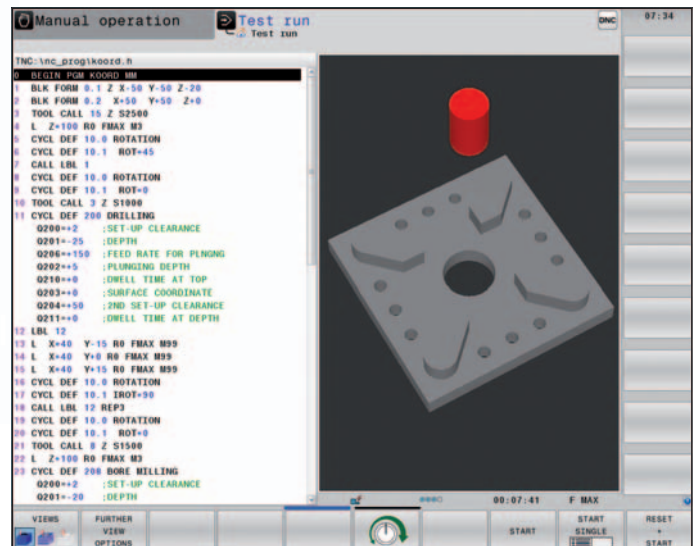

– Fast availability of all information

Do you have questions on a programming step but your User's Manual is not at hand? No problem: Both the TNC 640 and the TNC 640 programming station feature **TNCguide, a convenient help system** that can display the user documentation in a separate window.

You can activate TNCguide by simply pressing the help key on the TNC keyboard or by clicking any soft key when the mouse pointer has a question mark. You switch the cursor by simply clicking the help symbol that is always visible on the TNC screen.

TNCguide usually displays the information in the immediate context of the element in question (context-sensitive help). This means that you immediately receive the relevant information. This function is particularly helpful with the soft keys. The method and effect of operation are explained in detail.

You can download the documentation in the desired language free of charge from the HEIDENHAIN homepage into the corresponding language directory on the TNC hard disk.

The following manuals are available in the help system:

- User's manual for Klartext conversational programming
- User's manual for cycle programming
- User's manual for ISO programming
- User's manual for the TNC 640 programming station (installed only with the programming station)

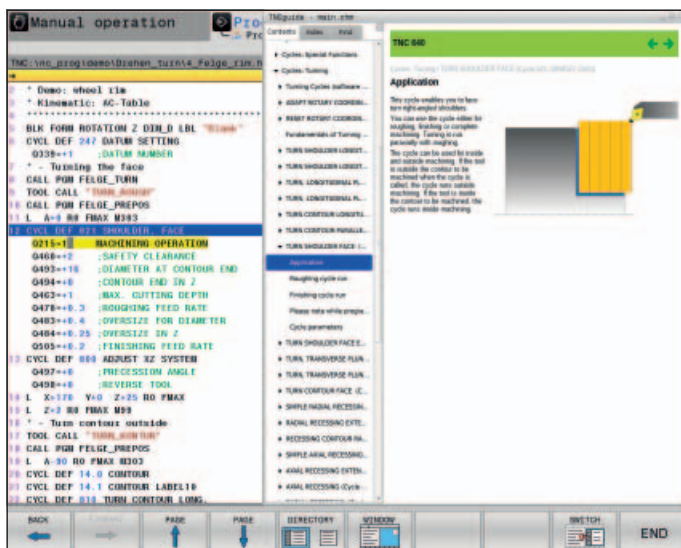

TNCguide integrated in the control, e.g. on the TNC 640 ...

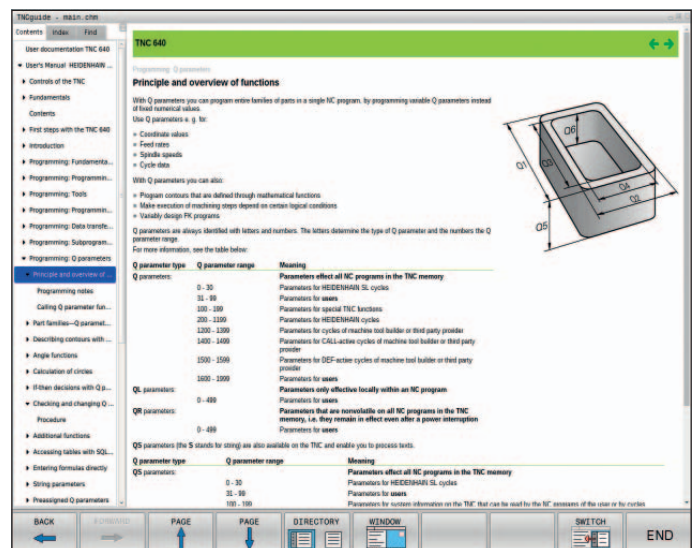

... or at the programming station.

Open for communication

– The TNC 640 understands CAD files

DXF converter (option)

Why program complex contours when your drawing is already in DXF format anyway? You can open DXF files directly on the TNC 640 in order to extract contours or machining positions from it. This not only saves time otherwise spent on programming and testing, you can also be sure that the finished contour is exactly according to the design engineer's specifications.

The DXF format—particularly the DXF format supported by the TNC 640—is very widespread and is supported by all common CAD and graphics programs.

After the DXF file has been loaded onto the TNC from the network or a USB stick, you can open the file in the file manager of the TNC, just like an NC program.

As a rule, DXF files contain multiple layers, with which the design engineer organizes the drawing. So that as little unnecessary information as possible appears on the screen during selection of the contours, with a keystroke you can hide all **excessive layers** contained in the DXF file. This requires a keyboard with touchpad or an external pointing device. The TNC can select a contour train even if it has been saved over **different layers**.

The TNC also supports you when **defining the workpiece datum**. The datum of the drawing for the DXF file is not always located in a manner that lets you use it directly as a reference point for the workpiece, especially when the drawing contains multiple views. For this reason, the TNC has a function with which you can shift the drawing datum to a suitable location simply by clicking an element.

You can define the following locations as reference point:

- The beginning, end or mid-point of a line
- The beginning, end or center point of a circular arc
- Quadrant transitions or center point of a circle
- Intersection of two lines, regardless of whether it is located inside or outside the programmed segments
- Intersection of a line and a circular arc
- Intersection of a line and a circle

If multiple intersections can result between two elements (e.g., between a straight line and a circle), you can select the correct intersection with a mouse click.



Contour selection is exceptionally user friendly. You select any element by clicking it with the mouse. As soon as you select a second element, the TNC detects your desired direction of machining, and starts the **automatic contour detection**. The TNC automatically selects all clearly identifiable contour elements until the contour closes or branches out. There you click the immediately following contour element. In this way you can define even extensive contours with just a few mouse clicks. If desired, you can also shorten, lengthen or interrupt the contour elements. You can then easily copy the selected contours over the clipboard into an existing Klartext program.

But you can also select **machining positions** and save them as point files, particularly in order to use drilling positions or starting points for pocket machining. This can be done very easily: Using the mouse, simply select the desired area. In a pop-up window with a filter function, the TNC displays all hole diameters that are within the area you have selected. To select the desired hole diameters and restrict the number of hole positions, simply click the corresponding filter symbol to change the filter limits.

A zoom function and various possibilities for settings round out the functionality of the DXF converter. In addition, you can define the resolution of the contour program to be output in case you want to use it on older TNC controls, or a transition tolerance if occasionally the elements do not quite adjoin.

CAD viewer

The integrated CAD viewer allows you to open standardized 3-D CAD models and drawings directly on the TNC 640. This powerful viewer is a simple and simultaneously efficient solution for displaying CAD design data on the shop floor. Different viewing options and functions for rotating and zooming enable you to visually monitor and analyze your CAD data in detail.

Moreover, you can also use the viewer to find position values and dimensions from the 3-D model. And you can set the datum as desired and select elements in the model. The CAD viewer shows the coordinates of the selected elements in a window.

The TNC 640 can display the following file formats:

- STEP files (.STP and .STEP)
- IGES files (.IGS and .IGES)
- DXF files (.DXF)

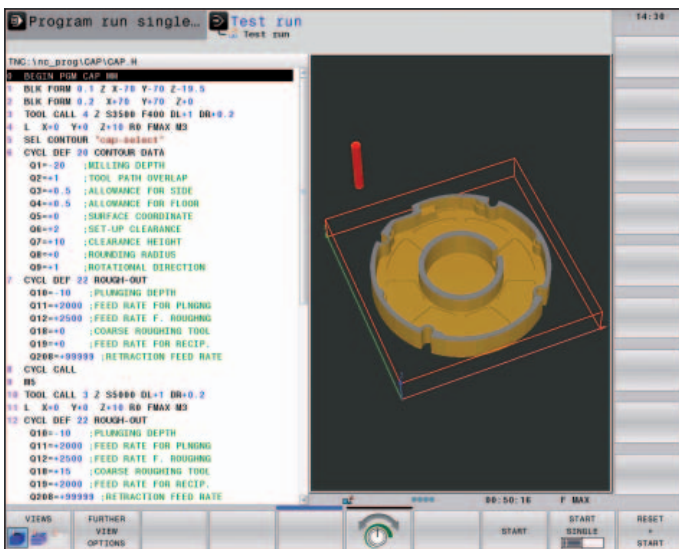

Part program on the basis of the imported DXF file

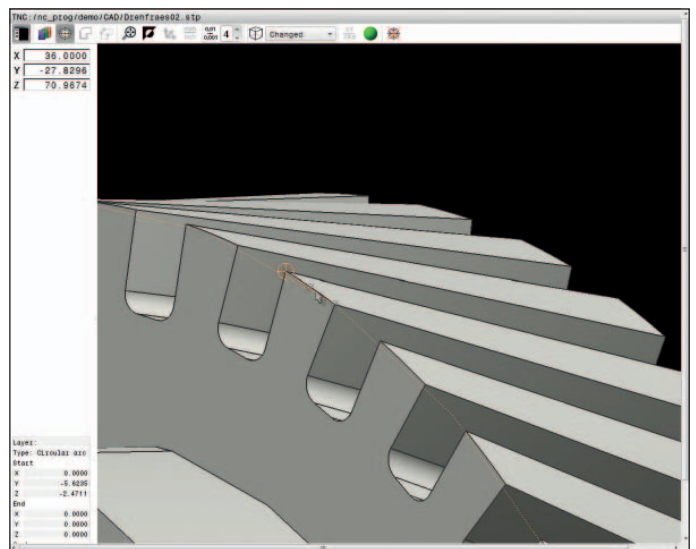

Display of a 3-D model in the CAD viewer

Open for communication

– Uniformly digital order management with Connected Machining

connected + machining

The well functioning transfer of knowledge contributes decisively to the success of any company. To transfer knowledge quickly and without loss, effective communication via e-mail is just as much a matter of course as the universal availability of electronic production documents or the transfer of data to merchandise management systems and production activity control systems. The tools and raw materials in stock, tool data, fixture setups, CAD data, NC programs, and inspection instructions must be available to machine operators across all shifts. Economic manufacturing therefore demands an efficiently working process chain and a numeric control connected to this network.

The TNC 640, with its **Connected Machining** package of functions, integrates itself flexibly into your process chain and helps you to optimize the transfer of knowledge within your

company. So also grant your workshop all the information available in your company. **Connected Machining** makes uniformly digital order management possible in networked manufacturing. You thus profit from:

- Easy data usage
- Time-saving procedures
- Transparent processes

The networked TNC 640

By integrating the TNC 640 with its **Connected Machining** functions in your company network, the control connects the workshop with PCs, programming stations, and other data storage devices in other areas of your company:

- Design
- Programming
- Simulation
- Production planning
- Production

Even in its standard version, the TNC 640 features a latest-generation Gigabit Ethernet interface in addition to its RS-232-C/V.24 data interface. The TNC 640 communicates with NFS servers and Windows networks in TCP/IP protocol without needing additional software. The fast data transfer at rates of up to 1000 Mbps guarantees very short transfer times. The TNC 640 offers the best technological conditions for **Connected Machining**, the networking of the control in the workshop with all areas of your company that accompany production.

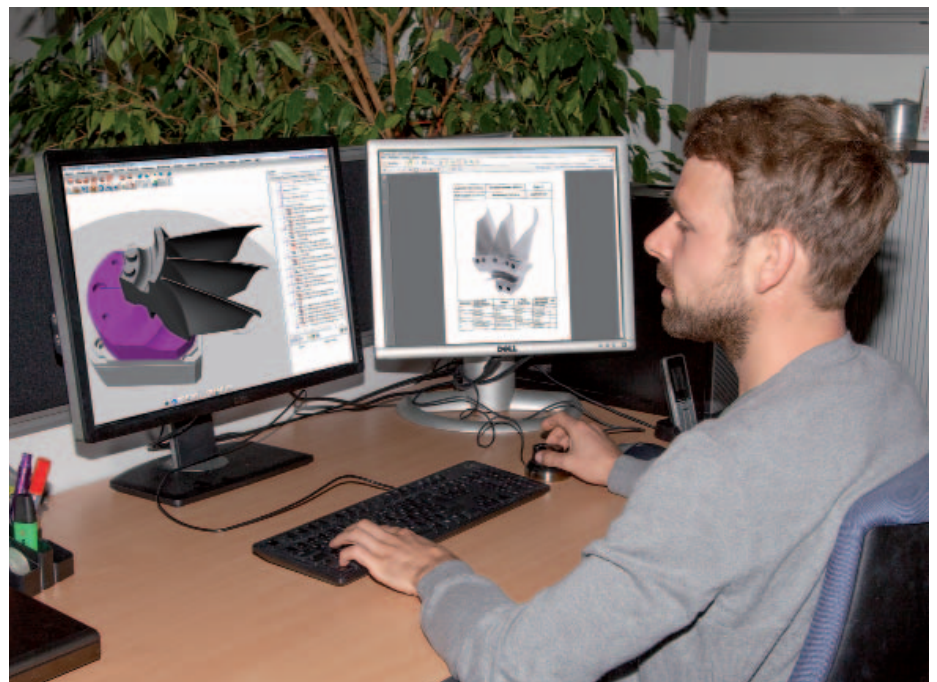
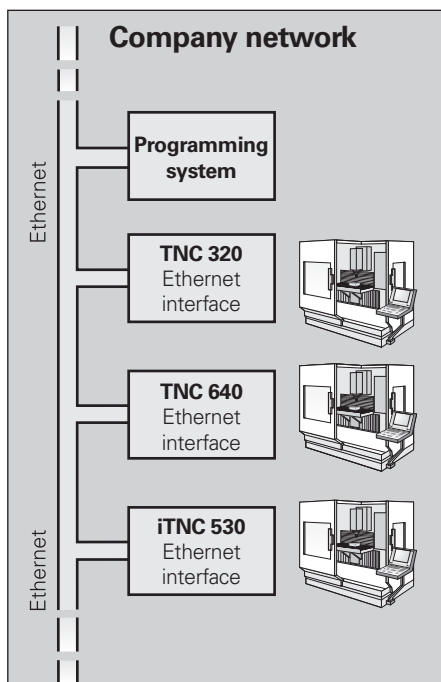

Standard performance range

In order to be able to use the data that you have transmitted to the control via the standard network connections, the TNC 640 offers you several interesting applications, even as part of the standard scope of functions. A CAD viewer, PDF viewer or the web browser Mozilla Firefox make the simplest form of **Connected Machining** possible: access to manufacturing process data right at the control.

The operation of web-based documentation software or ERP systems is just as possible here as access to your e-mail inbox. The following file formats can also be opened directly on the TNC:

- Text files ending with .txt or .ini
- Graphic files ending with .gif, .bmp, .jpg, or .png
- Table files ending with .xls or .csv
- HTML files

Data transfer with Connected Machining

An additional solution for uniformly digital order management as part of **Connected Machining** is the free **TNCremo** software for PCs. With it, and even over the Ethernet interface, you can

- transfer remotely stored part programs and tool or pallet tables in both directions, and
- start the machine.

With the powerful **TNCremoPlus** software for PCs you can also transfer the screen contents of the control to your PC using the live-screen function.

Using order-related data on the control

With the **REMOTE DESKTOP MANAGER** (option 133) you operate a Windows PC directly from the TNC 640. You can access IT systems of the process chain directly from the control, and you also profit from much more efficient setup procedures by eliminating tedious journeys between the machine and the office. Technical drawings, CAD data, NC programs, tool data, work instructions, parts lists and warehouse information are digitally available at the machine. E-mails can be sent and received very easily. With a simple keystroke on the machine operating panel you can switch between the control screen and the screen of the Windows PC. It can be a computer in the local network or an industrial PC in the machine's electrical cabinet.

With the IPC 6641, HEIDENHAIN offers an industrial PC with very high computing power and the newest processor architecture for installation in an electrical cabinet. This enables you to easily and efficiently solve even the most computationally intensive tasks in CAD/CAM on your TNC control.

Detailed data for an optimal organization of the production process

HEIDENHAIN DNC* has several functions, including the connection of TNC controls to merchandise management systems and production activity control systems. For example, this interface can be used for the configuration of automatic feedback messages about active production processes. This increases transparency in manufacturing even with a batch size of one and supports timely order management.

With the TNC 640 and **Connected Machining**, uniformly digital order management becomes surprisingly simple. Optimize your processes and use the full innovative potential of your workshop.

* The machine must be prepared by the machine tool builder for this function.

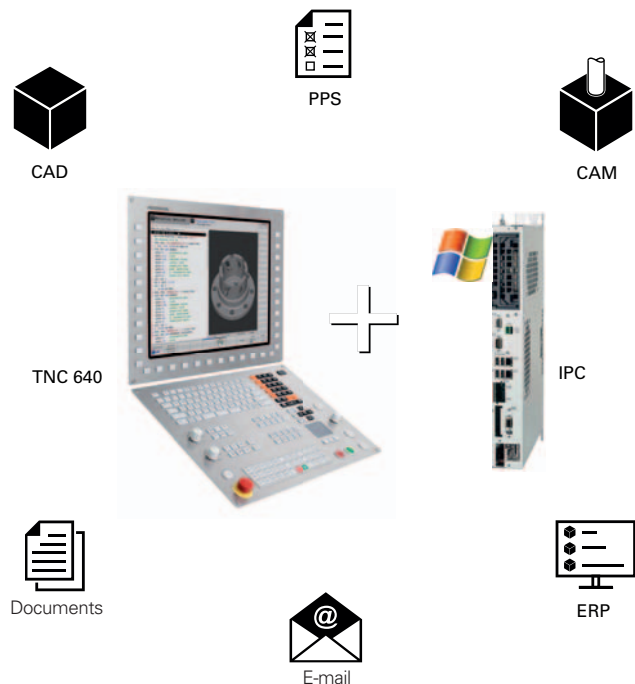

Open for communication

– The TNC 640 programming station

Why a programming station?

It's well known that it is easy to create part programs on a TNC 640 at the machine, even while another part is being machined. Nevertheless, short reloading times and other machining tasks can often hinder any prolonged or concentrated programming work. With the TNC 640 programming station you have the capability to program just as you do at the machine, but away from the noise and distractions of the shop floor.

Creating programs

Programming, testing and optimizing HEIDENHAIN Klartext or DIN/ISO programs with the programming station substantially reduces machine idle times. You need not adjust your way of thinking—every keystroke fits. On the programming station you program on the same keyboard as at the machine.

Testing of programs created offline

Of course you can also test programs that were written on a CAD/CAM system. The various views of the program verification graphics help you to easily spot contour damage and hidden details.

Training with the programming station

Because the TNC 640 programming station is based on the same software as the TNC 640, it is ideally suited for apprentice and advanced training. The program is entered on the original keyboard unit. Even the test run functions exactly as it does on the machine. This gives the trainee the experience needed to enable him to safely operate the machine later.

Because the TNC 640 can be programmed in Klartext and in DIN/ISO, the TNC 640 programming station can also be used in schools for TNC programming training.

Your workstation

The programming station software runs on a PC. The PC screen shows you the TNC user interface as on the control, and offers the familiar graphic support. Depending on the version of the programming station, there are several types of possibilities for using it.

The free **demo version** contains all functions of the TNC 640, and permits short programs to be saved. It is programmed via the PC keyboard.

On the version with a **TNC operating panel** you then create your programs as always, on a keyboard with the same function keys as on the control of the machine. It also has a PC keyboard for G-code programming, file names and comments.

But you can also work without the TNC operating panel: a **virtual keyboard** simulating the TE appears on the PC screen. It provides the TNC 640's most important dialog initiation keys.



Workpiece measurement

– Setup, presetting and measuring with touch trigger probes

Workpiece touch probes* from HEIDENHAIN help you to reduce costs in the workshop and in series production: Together with the TNC 640, touch probes can automatically perform setup, measuring and inspection functions.

The stylus of a TS touch trigger probe is deflected upon contact with a workpiece surface. At that moment the TS generates a trigger signal that, depending on the model, is transmitted either by cable or over an infrared beam to the control.

The touch probe* is inserted directly into the machine tool spindle. It can be equipped with various shanks depending on the machine. The ruby ball tips are available in several diameters, and the styli in different lengths.

* Machine and TNC must be specially adapted by the machine tool builder.

Touch probes with **cable connection for signal transmission** for machines with manual tool change and for grinding machines and lathes:

TS 260 – New generation, axial or radial cable

Touch probe with **radio or infrared signal transmission** for machines with automatic tool change:

TS 460 – New-generation standard touch probe for radio and infrared transmission with compact dimensions, energy-saving mode, optional collision protection and thermal decoupling

TS 444 – Battery-free voltage supply through integrated air turbine generator from compressed air, for infrared transmission, with compact dimensions

TS 740 – High probing accuracy and repeatability, low probing force, with infrared transmission



TS 460 with collision protection

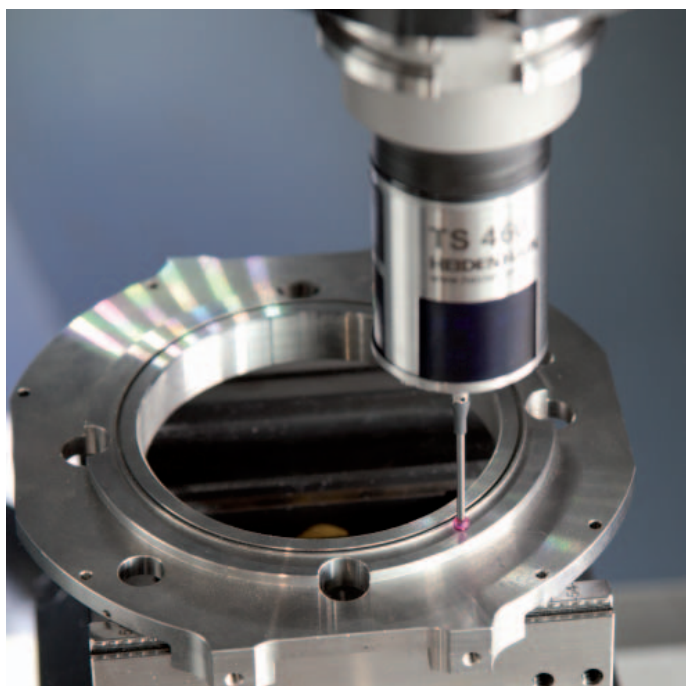

More information about workpiece touch probes is available on the Internet at www.tastsysteme.de or in the *Touch Probes* brochure.

Tool measurement

– Measuring length, radius and wear directly in the machine

The tool is of course a decisive factor in ensuring a consistently high level of production quality. This means that an exact measurement of the tool dimensions and periodic inspection of the tool for wear and breakage, as well as the shape of each tooth, are necessary. HEIDENHAIN offers the TT trigger tool touch probes as well as the non-contacting TL Nano and TL Micro laser systems for tool measurement.

The systems are installed directly in the machine's workspace, where they permit tool measurement either before machining or during interruptions.

The **TT tool touch probes** measure the tool length and radius. When probing the rotating or stationary tool, e.g. during individual tooth measurement, the contact plate is deflected and a trigger signal is transmitted directly to the TNC 640.

The **TT 160** uses signal transmission by cable, whereas the **TT 460** operates with wireless signal transmission over radio or an infrared beam. It is therefore particularly suitable for use on rotary and tilting tables.

The **TL Nano** and **TL Micro laser systems** are available for various maximum tool diameters. Using a laser beam, they probe the tool without contact, and can detect form errors of individual teeth along with the tool length and radius.



TT 460



TL Micro

More information about tool touch probes is available on the Internet at www.tastsysteme.de or in the *Touch Probes* brochure.

Inspecting and optimizing machine accuracy

– Calibrating rotary axes simply with KinematicsOpt (option)

Accuracy requirements are becoming increasingly stringent, particularly in the area of 5-axis machining. Complex parts need to be manufactured with precision and reproducible accuracy even over long periods.

The TNC function **KinematicsOpt** is an important component to help you meet these high requirements: With a HEIDENHAIN touch probe inserted, a cycle measures your machine's rotary axes fully automatically. The results of measurement are the same regardless of whether the axis is a rotary table, a tilting table or a swivel head.

To measure the rotary axes, a calibration sphere is fixed at any position on the machine table and probed with the HEIDENHAIN touch probe. But first you define the resolution of the measurement and define for each rotary axis the range that you want to measure.

From the measured values, the TNC calculates the static tilting accuracy. The software minimizes the spatial error arising from the tilting movements and, at the end of the measurement process, automatically saves the machine geometry in the respective machine constants of the kinematics description.

Of course, a comprehensive log file is also saved with the actual measured values and the measured and optimized dispersion (measure for the static tilting accuracy), as well as the actual compensation values.

An especially rigid calibration sphere is necessary for optimum use of KinematicsOpt. This helps to reduce deformations that occur as the result of probing forces. That is why HEIDENHAIN offers calibration spheres with highly rigid holders that are available in various lengths.

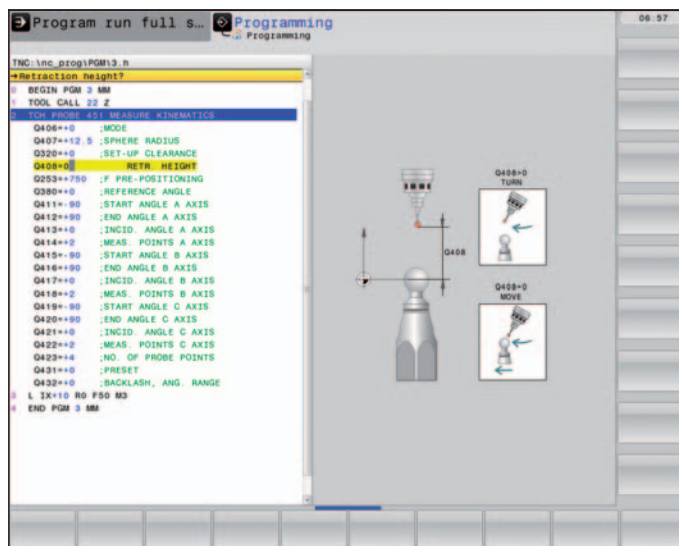

Positioning with the electronic handwheel

– Delicate axis traverse

To set up the workpiece, you can use the direction keys to move the machine axes manually. A simpler and more sensitive way, however, is to use the electronic handwheels from HEIDENHAIN.

You can move the axis slide through the feed motors in direct relation to the rotation of the handwheel. For delicate operations you can set the transmission ratio to certain preset distances per handwheel revolution.

HR 130 and HR 150 panel-mounted handwheels

The panel-mounted handwheels from HEIDENHAIN can be integrated in the machine operating panel or mounted at another location on the machine. An adapter permits connection of up to three HR 150 electronic handwheels.

HR 510, HR 520 and HR 550 portable handwheels

The HR 510, HR 520 and HR 550 are particularly helpful for when you have to work close to the machine's working space. The axis keys and certain functional keys are integrated in the housing. In this way you can switch axes and set up the machine at any time—regardless of where you happen to be standing. As a wireless handwheel, the HR 550 is ideal for use on large machine tools. If you no longer need the handwheel, just attach it to the machine somewhere by its built-in magnets.

Expanded feature content of HR 520 and HR 550

- Traverse distance per revolution can be set
- Display for operating mode, actual position value, programmed feed rate and spindle speed, error messages
- Override potentiometer for feed rate and spindle speed
- Selection of axes via keys or soft keys
- Keys for continuous traverse of the axes
- Emergency stop button
- Actual position capture
- NC start/stop
- Spindle on/off
- Soft keys for machine functions defined by the machine tool builder



HR 550



Overview

– User functions

User functions	Default	Option	
Short description	<ul style="list-style-type: none"> • ○ 	<ul style="list-style-type: none"> 0-7 77 78 	<p>Basic version: 3 axes plus spindle 4th NC axis plus auxiliary axis or</p> <p>A total of 14 additional NC axes or 13 additional NC axes plus second spindle</p> <ul style="list-style-type: none"> • Digital current and speed control
Program entry	<ul style="list-style-type: none"> • • 	42	<p>HEIDENHAIN Klartext conversational language DIN/ISO programming Direct loading of contours or machining positions from DXF files and saving as Klartext conversational language contouring program or point table</p>
Position entry	<ul style="list-style-type: none"> • • • 		<p>Nominal positions for lines and arcs in Cartesian coordinates or polar coordinates Incremental or absolute dimensions Display and entry in mm or inches</p>
Tool compensation	<ul style="list-style-type: none"> • • 	9	<p>Tool radius in the working plane and tool length Radius compensated contour look ahead for up to 99 blocks (M120) Three-dimensional tool-radius compensation for changing tool data without having to recalculate an existing program</p>
Tool tables	<ul style="list-style-type: none"> • 		Multiple tool tables with any number of tools
Cutting data	<ul style="list-style-type: none"> • 		Automatic calculation of spindle speed, cutting speed, feed per tooth and feed per revolution
Constant contour speed	<ul style="list-style-type: none"> • • 		<p>Relative to the path of the tool center Relative to the tool's cutting edge</p>
Parallel operation	<ul style="list-style-type: none"> • 		Creating a program with graphical support while another program is being run
3-D machining	<ul style="list-style-type: none"> • 	<ul style="list-style-type: none"> 9 9 9 9 9 	<p>Motion control with highly smoothed jerk 3-D tool compensation through surface normal vectors Using the electronic handwheel to change the angle of the swivel head during program run without affecting the position of the tool point (TCPM = Tool Center Point Management) Keeping the tool normal to the contour Tool radius compensation normal to the tool direction Manual traverse in the active tool-axis system</p>
Machining with a rotary table		8 8	<p>Programming of cylindrical contours as if in two axes Feed rate in distance per minute</p>
Turning		50 50 50 50 50 50 50 50 50 50 50	<p>Program-controlled switchover between milling and turning Constant surface speed Tool-tip radius compensation Cycles for roughing, finishing, recessing, thread turning and recess turning Blank form updated in contour cycles Turning-specific contour elements for recesses and undercuts Orientation of the turning tool for outside or inside machining Inclined turning Speed limiting Eccentric turning (additionally required: option 135)</p>

User functions	Default	Option	
Programming aids	<ul style="list-style-type: none"> • • • • • • 		<ul style="list-style-type: none"> Calculator Complete list of all current error messages Context-sensitive help function for error messages TNCguide: The integrated help system. User information available directly on the TNC 640 Graphic support for programming cycles Comment and structure blocks in the NC program
Teach-In	<ul style="list-style-type: none"> • 		Actual positions can be transferred directly into the NC program
Test graphics Display modes	<ul style="list-style-type: none"> • • • 		<ul style="list-style-type: none"> Graphic simulation before milling operations, even while another program is running Plan view / projection in 3 planes / 3-D view, also in tilted working plane/3-D line graphics Detail zoom
Programming graphics	<ul style="list-style-type: none"> • 		In the Programming and Editing mode, the contours of the NC blocks are drawn on screen while they are being entered (2-D pencil-trace graphics), even while another program is running
Program-run graphics Display modes	<ul style="list-style-type: none"> • • 		<ul style="list-style-type: none"> Real-time graphic simulation during execution of the milling program Plan view / projection in three planes / 3-D view
Machining time	<ul style="list-style-type: none"> • • 		<ul style="list-style-type: none"> Calculation of machining time in the Test Run operating mode Display of the current machining time in the Program Run operating modes
Returning to the contour	<ul style="list-style-type: none"> • • 		<ul style="list-style-type: none"> Mid-program startup in any block in the program, returning the tool to the calculated nominal position to continue machining Program interruption, contour departure and return
Reference-point management	<ul style="list-style-type: none"> • 		One table for storing any reference points
Datum tables	<ul style="list-style-type: none"> • 		Multiple datum tables for storing workpiece-specific datums
Pallet tables	<ul style="list-style-type: none"> • 		Workpiece-oriented execution of pallet tables with any number of entries for selection of pallets, NC programs and datums
Touch probe cycles	<ul style="list-style-type: none"> • • • • 	48	<ul style="list-style-type: none"> Calibrating the touch probe Compensation of workpiece misalignment, manual or automatic Datum setting, manual or automatic Automatic tool and workpiece measurement KinematicsOpt: Automatic measurement and optimization of machine kinematics
Parallel secondary axes	<ul style="list-style-type: none"> • • • 		<ul style="list-style-type: none"> Compensating movement in the secondary axes U, V, W through the principal axes X, Y, Z Including movements of the parallel axis in the position display of the associated principal axis (sum display) Defining the principal and secondary axes in the NC program makes it possible to run programs on different machine configurations
Conversational languages	<ul style="list-style-type: none"> • 		English, German, Czech, French, Italian, Spanish, Portuguese, Swedish, Danish, Finnish, Dutch, Polish, Hungarian, Russian (Cyrillic), Chinese (traditional, simplified), Slovenian, Slovak, Norwegian, Korean, Turkish, Romanian
CAD viewer	<ul style="list-style-type: none"> • 		Display CAD models on the TNC

Overview

- Accessories
- Options

Accessories	
Electronic handwheels	<ul style="list-style-type: none"> • One HR 510 portable handwheel or • One HR 520 portable handwheel or • One HR 550 portable wireless handwheel or • One HR 130 panel-mounted handwheel or • Up to three HR 150 panel-mounted handwheels through an HRA 110 handwheel adapter
Workpiece measurement	<ul style="list-style-type: none"> • TS 260: 3-D touch trigger probe with cable connection or • TS 460: 3-D touch trigger probe with infrared transmission or • TS 444: 3-D touch trigger probe with infrared transmission or • TS 640: 3-D touch trigger probe with infrared transmission or • TS 740: 3-D touch trigger probe with infrared transmission
Tool measurement	<ul style="list-style-type: none"> • TT 160: 3-D touch trigger probe or • TS 460: 3-D touch trigger probe with infrared transmission • TL Nano: laser system for contact-free tool measurement or • TL Micro: laser system for contact-free tool measurement
Programming station	<p>Control software for PCs for programming, archiving, and training</p> <ul style="list-style-type: none"> • Single-station license with original control keyboard • Single-station license with virtual keyboard • Network license with virtual keyboard • Demo version (operated with PC keyboard—free of charge)
Software for PCs	<ul style="list-style-type: none"> • TeleService: Software for remote diagnosis, monitoring, and operation • CycleDesign: Software for creating your own cycle structure • TNCremo: Data transmission software—free of charge • TNCremoPlus: Software for data transfer with live-screen function

Option number	Option	As of NC software 34059x-	ID	Remark
0 1 2 3 4 5 6 7	Additional axis	01	354540-01 353904-01 353905-01 367867-01 367868-01 370291-01 370292-01 370293-01	Additional control loops 1 to 8
8	Advanced function set 1	01	617920-01	<p>Machining with a rotary table</p> <ul style="list-style-type: none"> • Programming of cylindrical contours as if in two axes • Feed rate in distance per minute <p>Interpolation: Circular in 3 axes with tilted working plane</p> <p>Coordinate transformation: Tilting the working plane, PLANE function</p>
9	Advanced function set 2	01	617921-01	<p>Interpolation: Linear in 5 axes</p> <p>3-D machining</p> <ul style="list-style-type: none"> • 3-D tool compensation through surface normal vectors • Using the electronic handwheel to change the angle of the swivel head during program run without affecting the position of the tool point (TCPM = Tool Center Point Management) • Keeping the tool normal to the contour • Tool radius compensation normal to the tool direction • Manual traverse in the active tool-axis system
18	HEIDENHAIN DNC	01	526451-01	Communication with external Windows applications over COM component

Option number	Option	As of NC software 34059x-	ID	Remark
23	Display step	01	632986-01	Display step to 0.01 µm or 0.00001°
40	DCM collision	02	526452-01	Dynamic Collision Monitoring (DCM)
42	DXF converter	02	526450-01	Loading and converting DXF contours
45	Adaptive Feed Control (AFC)	02	579648-01	Adaptive Feed Control
46	Python OEM process	01	579650-01	Python application on the TNC
48	KinematicsOpt	01	630916-01	Touch-probe cycles for automatic measurement of rotary axes
50	Turning	01	634608-01	Turning functions: <ul style="list-style-type: none"> • Tool management for turning • Tool-tip radius compensation • Switching between milling and turning modes of operation • Lathe-specific contour elements • Package of turning cycles • Hobbing
52	KinematicsComp	05	661879-01	Compensate spatial error in rotary and linear axes
77	4 additional axes	01	634613-01	4 additional control loops
78	8 additional axes	01	634614-01	8 additional control loops
92	3D-Tool Comp	07	679678-01	3-D radius compensation depending on the tool's contact angle
93	Extended tool management	01	676938-01	Extended tool management
96	Advanced spindle interpolation	05	751653-01	Cycles for interpolation turning
131	Spindle synchronism	05	806270-01	Speeds of two or more spindles can be synchronized at equal angles, with a transmission ratio, and/or with a defined offset
133	Remote Desktop Manager	01	894423-01	Display and remote operation of external computer units (e.g. a Windows PC)
135	Synchronizing functions	04	1085731-01	RTC: Real-Time Coupling function for synchronizing axes and spindles
136	Visual Setup Control	06	1099457-01	VSC: Camera-based monitoring of the setup situation
141	Cross Talk Comp.	02	800542-01	CTC: Compensation of axis couplings
142	Pos. Adapt. Control	02	800544-01	PAC: Position-dependent adaptation of the control parameters
143	Load Adapt. Control	02	800545-01	LAC: Load-dependent adaptation of the control parameters
144	Motion Adapt. Control	02	800546-01	MAC: Motion-dependent adaptation of control parameters
145	Active Chatter Control	02	800547-01	ACC: Active suppression of chatter
146	Active Vibration Damping	04	800548-01	AVD: Active suppression of vibration

Overview

– Specifications

Specifications	Default	Option
Components	<ul style="list-style-type: none"> • • • • 	MC main computer CC or UEC controller units BF TFT flat-panel display with soft keys (15.1-inch or 19-inch) TE control panel (suitable for 15.1-inch or 19-inch screens)
Operating system	<ul style="list-style-type: none"> • 	HEROS 5 real-time operating system for machine control
Memory	<ul style="list-style-type: none"> • • 	RAM memory: 4 GB Program memory: SSDR approx. 21 GB HDR approx. 144 GB
Input resolution and display step	<ul style="list-style-type: none"> • • 23 23	Linear axes: to 0.1 μm Angular axes: to 0.0001° Linear axes: to 0.01 μm Angular axes: to 0.00001°
Input range	<ul style="list-style-type: none"> • 	Maximum 999 999 999 mm or 999 999 999°
Interpolation	<ul style="list-style-type: none"> • • • • 9 8	Linear in 4 axes Linear in 5 axes (subject to export permit) Circular in 2 axes Circular in 3 axes with tilted working plane Helical: superimposition of circular and straight paths
Block processing time	<ul style="list-style-type: none"> • 	0.5 ms (3-D straight line without radius compensation)
Axis feedback control	<ul style="list-style-type: none"> • • • • 	Position loop resolution: Signal period of the position encoder/1024 Position controller cycle time: 200 μs (100 μs with option 49) Speed controller cycle time: 200 μs (100 μs with option 49) Current controller cycle time: minimum 100 μs (minimum 50 μs with option 49)
Range of traverse	<ul style="list-style-type: none"> • 	Maximum 100 m (3937 inches)
Spindle speed	<ul style="list-style-type: none"> • 	Maximum 100 000 rpm (with 2 pole pairs)
Error compensation	<ul style="list-style-type: none"> • • 	Linear and nonlinear axis error, backlash, reversal peaks during circular movements, reversal error, thermal expansion Static friction, sliding friction
Data interfaces	<ul style="list-style-type: none"> • • • • 18	One each RS-232-C/V.24 max. 115 kbps Extended data interface with LSV2 protocol for remote operation of the TNC over the data interface with the HEIDENHAIN software TNCremo or TNCremoPlus 2 x Gigabit Ethernet interface 1000BASE-T 5 x USB (1 x front USB 2.0, 4 x USB 3.0) HEIDENHAIN-DNC for communication between a Windows application and TNC (DCOM interface)
Diagnostics	<ul style="list-style-type: none"> • 	Fast and simple troubleshooting through integrated diagnostic aids
Ambient temperature	<ul style="list-style-type: none"> • • 	Operation: +5 °C to +40 °C Storage: –20 °C to +60 °C

– Comparison of controls

Comparison of controls	TNC 620 NC SW 81760x-04	TNC 640 NC SW 34059x-07	iTNC 530 NC SW 60642x-04
Area of application	Standard milling	High-end milling/turning	High-end milling
• Simple machining centers (up to 5 axes + 1 spindle)	●	●	●
• Machine tools/machining centers (up to 18 axes + 2 spindles)	–	●	●
• Milling/turning operations (up to 18 axes + 2 spindles)	–	Option	–
Program entry			
• HEIDENHAIN Klartext conversational	●	●	●
• According to ISO	●	●	●
• DXF converter	Option	Option	Option
• CAD viewer	●	●	Option
• FK free contour programming	Option	●	●
• Extended milling and drilling cycles	Option	●	●
• Turning cycles	–	Option	–
NC program memory	1.8 GB	> 21 GB	> 21 GB
5-axis and high-speed machining	Option	Option	Option
Block processing time	1.5 ms	0.5 ms	0.5 ms
Input resolution and display step (standard/option)	0.1 µm/0.01 µm	0.1 µm/0.01 µm	0.1 µm/–
New design of the screen and keyboard	15-inch screen	15/19-inch screen	15/19-inch screen
Optimized user interface	●	●	–
Adaptive Feed Control (AFC)	–	Option	Option
Active Chatter Control (ACC)	Option	Option	Option
Dynamic Collision Monitoring (DCM)	–	Option	Option
KinematicsOpt	Option	Option	Option
KinematicsComp	–	Option	Option
Touch probe cycles	Option	●	●
Pallet editor	Option	●	●
Parallel axis function	●	●	–

- Standard
- Not available

HEIDENHAIN

DR. JOHANNES HEIDENHAIN GmbH

Dr.-Johannes-Heidenhain-Straße 5

83301 Traunreut, Germany

☎ +49 8669 31-0

FAX +49 8669 32-5061

E-mail: info@heidenhain.de

www.heidenhain.de

Vollständige und weitere Adressen siehe www.heidenhain.de
For complete and further addresses see www.heidenhain.de

DE	HEIDENHAIN Vertrieb Deutschland 83301 Traunreut, Deutschland ☎ 08669 31-3132 FAX 08669 32-3132 E-Mail: hd@heidenhain.de	ES	FARRESA ELECTRONICA S.A. 08028 Barcelona, Spain www.farresa.es	PL	APS 02-384 Warszawa, Poland www.heidenhain.pl
	HEIDENHAIN Technisches Büro Nord 12681 Berlin, Deutschland ☎ 030 54705-240	FI	HEIDENHAIN Scandinavia AB 01740 Vantaa, Finland www.heidenhain.fi	PT	FARRESA ELECTRÓNICA, LDA. 4470 - 177 Maia, Portugal www.farresa.pt
	HEIDENHAIN Technisches Büro Mitte 07751 Jena, Deutschland ☎ 03641 4728-250	FR	HEIDENHAIN FRANCE sarl 92310 Sèvres, France www.heidenhain.fr	RO	HEIDENHAIN Reprezentanță Romania Braşov, 500407, Romania www.heidenhain.ro
	HEIDENHAIN Technisches Büro West 44379 Dortmund, Deutschland ☎ 0231 618083-0	GB	HEIDENHAIN (G.B.) Limited Burgess Hill RH15 9RD, United Kingdom www.heidenhain.co.uk	RS	Serbia → BG
	HEIDENHAIN Technisches Büro Südwest 70771 Leinfelden-Echterdingen, Deutschland ☎ 0711 993395-0	GR	MB Milionis Vassilis 17341 Athens, Greece www.heidenhain.gr	RU	OOO HEIDENHAIN 115172 Moscow, Russia www.heidenhain.ru
	HEIDENHAIN Technisches Büro Südost 83301 Traunreut, Deutschland ☎ 08669 31-1345	HK	HEIDENHAIN LTD Kowloon, Hong Kong E-mail: sales@heidenhain.com.hk	SE	HEIDENHAIN Scandinavia AB 12739 Skärholmen, Sweden www.heidenhain.se
		HR	Croatia → SL	SG	HEIDENHAIN PACIFIC PTE LTD. Singapore 408593 www.heidenhain.com.sg
AR	NAKASE SRL. B1653AOX Villa Ballester, Argentina www.heidenhain.com.ar	HU	HEIDENHAIN Kereskedelmi Képviselet 1239 Budapest, Hungary www.heidenhain.hu	SK	KOPRETINA TN s.r.o. 91101 Trenčín, Slovakia www.kopretina.sk
AT	HEIDENHAIN Techn. Büro Österreich 83301 Traunreut, Germany www.heidenhain.de	ID	PT Servitama Era Toolsindo Jakarta 13930, Indonesia E-mail: ptset@group.gts.co.id	SL	NAVO d.o.o. 2000 Maribor, Slovenia www.heidenhain.si
AU	FCR Motion Technology Pty. Ltd Laverton North 3026, Australia E-mail: vicsales@fcrmotion.com	IL	NEUMO VARGUS MARKETING LTD. Tel Aviv 61570, Israel E-mail: neumo@neumo-vargus.co.il	TH	HEIDENHAIN (THAILAND) LTD Bangkok 10250, Thailand www.heidenhain.co.th
BE	HEIDENHAIN NV/SA 1760 Roosdaal, Belgium www.heidenhain.be	IN	HEIDENHAIN Optics & Electronics India Private Limited Chetpet, Chennai 600 031, India www.heidenhain.in	TR	T&M Mühendislik San. ve Tic. LTD. ŞTİ. 34775 Y. Dudullu – Ümraniye-Istanbul, Turkey www.heidenhain.com.tr
BG	ESD Bulgaria Ltd. Sofia 1172, Bulgaria www.esd.bg	IT	HEIDENHAIN ITALIANA S.r.l. 20128 Milano, Italy www.heidenhain.it	TW	HEIDENHAIN Co., Ltd. Taichung 40768, Taiwan R.O.C. www.heidenhain.com.tw
BR	DIADUR Indústria e Comércio Ltda. 04763-070 – São Paulo – SP, Brazil www.heidenhain.com.br	JP	HEIDENHAIN K.K. Tokyo 102-0083, Japan www.heidenhain.co.jp	UA	Gertner Service GmbH Büro Kiev 01133 Kiev, Ukraine www.heidenhain.ua
BY	GERTNER Service GmbH 220026 Minsk, Belarus www.heidenhain.by	KR	HEIDENHAIN Korea LTD. Gasan-Dong, Seoul, Korea 153-782 www.heidenhain.co.kr	US	HEIDENHAIN CORPORATION Schaumburg, IL 60173-5337, USA www.heidenhain.com
CA	HEIDENHAIN CORPORATION Mississauga, Ontario L5T2N2, Canada www.heidenhain.com	MX	HEIDENHAIN CORPORATION MEXICO 20290 Aguascalientes, AGS., Mexico E-mail: info@heidenhain.com	VE	Maquinaria Diekmann S.A. Caracas, 1040-A, Venezuela E-mail: purchase@diekmann.com.ve
CH	HEIDENHAIN (SCHWEIZ) AG 8603 Schwerzenbach, Switzerland www.heidenhain.ch	MY	ISOSERVE SDN. BHD. 43200 Balakong, Selangor E-mail: sales@isoserve.com.my	VN	AMS Co. Ltd HCM City, Vietnam E-mail: davidgoh@amsvn.com
CN	DR. JOHANNES HEIDENHAIN (CHINA) Co., Ltd. Beijing 101312, China www.heidenhain.com.cn	NL	HEIDENHAIN NEDERLAND B.V. 6716 BM Ede, Netherlands www.heidenhain.nl	ZA	MAFEMA SALES SERVICES C.C. Midrand 1685, South Africa www.heidenhain.co.za
CZ	HEIDENHAIN s.r.o. 102 00 Praha 10, Czech Republic www.heidenhain.cz	NO	HEIDENHAIN Scandinavia AB 7300 Orkanger, Norway www.heidenhain.no		
DK	TPTEKNIK A/S 2670 Greve, Denmark www.tp-gruppen.dk	PH	Machinebanks Corporation Quezon City, Philippines 1113 E-mail: info@machinebanks.com		

